

READ THIS FIRST

VENTILATOR USER GUIDE

MODEL 718WT



PERSONAL RESPONSIBILITY CODE

The member companies of FEMSA that provide emergency response equipment and services want responders to know and understand the following:

1. Firefighting and Emergency Response are inherently dangerous activities requiring proper training in their hazards and the use of extreme caution at all times.
2. It is your responsibility to read and understand any user's instructions, including purpose and limitations, provided with any piece of equipment you may be called upon to use.
3. It is your responsibility to know that you have been properly trained in Firefighting and/or Emergency Response and in the use, precautions, and care of any equipment you may be called upon to use.
4. It is your responsibility to be in proper physical condition and to maintain the personal skill level required to operate any equipment you may be called upon to use.
5. It is your responsibility to know that your equipment is in operable condition and has been maintained in accordance with the manufacturer's instructions.
6. Failure to follow these guidelines may result in death, burns or other severe injury.



Fire and Emergency Manufacturers and Services Association, Inc.
P.O. Box 147, Lynnfield, MA 01940 www.FEMSA.org

Copyright 2006 FEMSA. All Rights Reserved

This manual covers the description, cautions, operation and maintenance of the *Super Vac* Hydraulic Positive Pressure Ventilator
Model 718WT

 **WARNING** Read this manual before operating the ventilator.
Save this guide for future reference.

CONTENTS

1. BREAKAGE OR DAMAGE DURING SHIPMENT	3
2. GENERAL DESCRIPTION AND SPECIFICATIONS.....	4
3. PRODUCT SAFETY PRECAUTIONS	5
4. BEFORE OPERATING VENTILATOR.....	5
5. OPERATION.....	6
6. INLET AND DISCHARGE POSITION.....	8
7. PARTS LIST	9
8. EXPLODED VIEW DRAWING.....	10
9. WARRANTY.....	11
10. CONTACT INFORMATION.....	12

1. Breakage or Damage During Shipment

The transportation company is fully responsible for all shipping damage and will resolve problems promptly if you handle it correctly. Please read these instructions carefully.

Examine the contents of all shipping cases. If you find any damage, call your transportation agent at once and have them make a description on the freight or express bill describing the damage and the number of pieces. Then write us and we will send you the original bill of lading. Get a claim blank from the express or truck company. Fill the claim form out. Attach the claim blank to the original bill of lading together with a copy of our invoice. Attach a memo on which you show the value of the damaged goods. Mail or hand these papers to your local transportation agent. They will process your claim with reasonable promptness.

Please note, we cannot and will not enter claims for damages. If we filed claim here, it would be sent to your local freight agent for verification and investigation. This time can be saved by your filing the claim directly. Every consignee is on the ground floor and in contact with the local agent who inspects the damaged goods, and thus, each claim can be given individual attention.

Since our goods are packed to comply with the regulations of all railroad, truck, and express companies, we cannot allow deduction from any invoice because of any damage, however, be sure to file your claim promptly. Our goods are sold F.O.B. factory. We take receipt from the transportation company certifying that the goods were delivered to them in good order, and our responsibility ceases.

It is seldom that any breakage or damage occurs in any of our shipments, and in no case will the customer be out any expense if they follow the above instructions.

Be sure to keep all damaged goods subject to examination of the truck or express company inspector, who may call on you some time later. These damaged goods, of course, will belong to them, and they will inform you what to do with them. If you dispose of these damaged goods, your claim may not be paid.

2. General Description and Specifications

Super Vac ventilators are specifically designed to provide a convenient and portable source of air. *Super Vac* positive pressure ventilators are tested to AMCA PPV Standard 240-95, for use in extreme conditions.

Specifications¹

Model#	Engine	HP	Height x Width x Depth	Weight (lbs.)
718WT	POK	5.5	18.75" X 22" X 20.75"	66

¹ Specifications are subject to change without notification. Refer to model decal affixed to ventilator to determine actual specifications.



This ventilator is designed for high powered air movement. *Super Vac*'s propeller produces a greater intake of air and eliminates turbulence at the tips. Each blade is statically balanced for high efficiency and long life.

This document is designed to function as a quick start guide and not an in-depth comprehensive instructional manual. Please read all accompanying documents shipped with your ventilator. Due to the many features of powered equipment thorough familiarity with the operating controls is essential to assure safe and trouble free operation.

3. Product Safety Precautions **WARNING**

- Do not use the ventilator for purposes other than its' intended use.
- Wear eye and ear protection when operating the ventilator.
- Never operate ventilator while fatigued.
- Do not disassemble or modify the ventilator in any way. Doing so may lead to mechanical failure or personal injury.
- Do not wear loose clothing that could become entangled in the operating ventilator.
- Never permit anyone to operate ventilator without proper instruction.
- Do not operate ventilator without proper inlet or outlet guards in place. If guards are missing or damaged, contact factory for replacements.
- Do not place fingers or other foreign objects through inlet or outlet guards. Should a foreign object enter the ventilator, immediately stop engine. Be certain all mechanical motion has stopped.
- Do not place or operate ventilator on unsteady tables, slanted surfaces or other unstable surfaces.
- Do not use chock blocks to increase the angle of the ventilator, severe injury could occur.

4. Before Operating Ventilator

-  **CAUTION** A complete inspection of the ventilator should be made prior to operation.
- Check all threaded fasteners for proper tightness.
-  **CAUTION** Inspect inlet and outlet guards for damage or missing pieces. Replace damaged or missing guards before operating ventilator.

5. Operation

Check ventilator inlet and outlet guards for obstructions. Check and remove from immediate surrounding area any objects that could be drawn into the ventilator intake.

Place ventilator in desired location before starting.

The two graphs allow you to establish with precision the best utilization of the apparatus.

Graph 1 depicts rotational speed and water consumption depending on input feed pressure.

Graph 2 depicts the usable horsepower depending on the driving torque.

Example: If the inlet pressure of the water supplied to the motor is 174 psi, and the resisting torque of the driven machine is 7.4 lb/ft, the rotational speed is 4560 rpm, water consumption is 117 gpm (graph 1) and the usable power is 5.5 HP (graph 2)

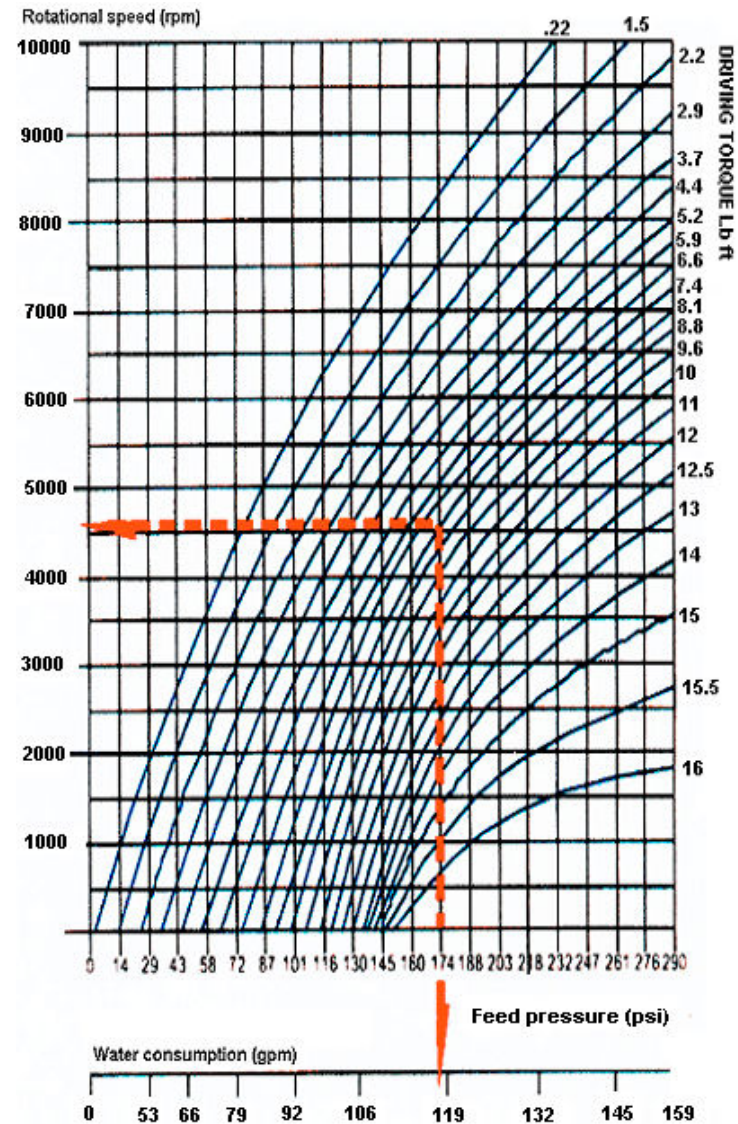

Rotational speed and water consumption based on feed pressure.

Inlet Pressure		Water Flow		Air Flow	
BAR	PSI	GPM	LPM	CFM	CMH
3.3	50	55	208	5168	8781
6.7	100	78	295	10112	17179
10.0	150	98	371	16178	27487
13.3	200	110	416	19100	32450
16.7	250	130	492	22470	38177

The maximum feed pressure is 300 psi (20 bar).

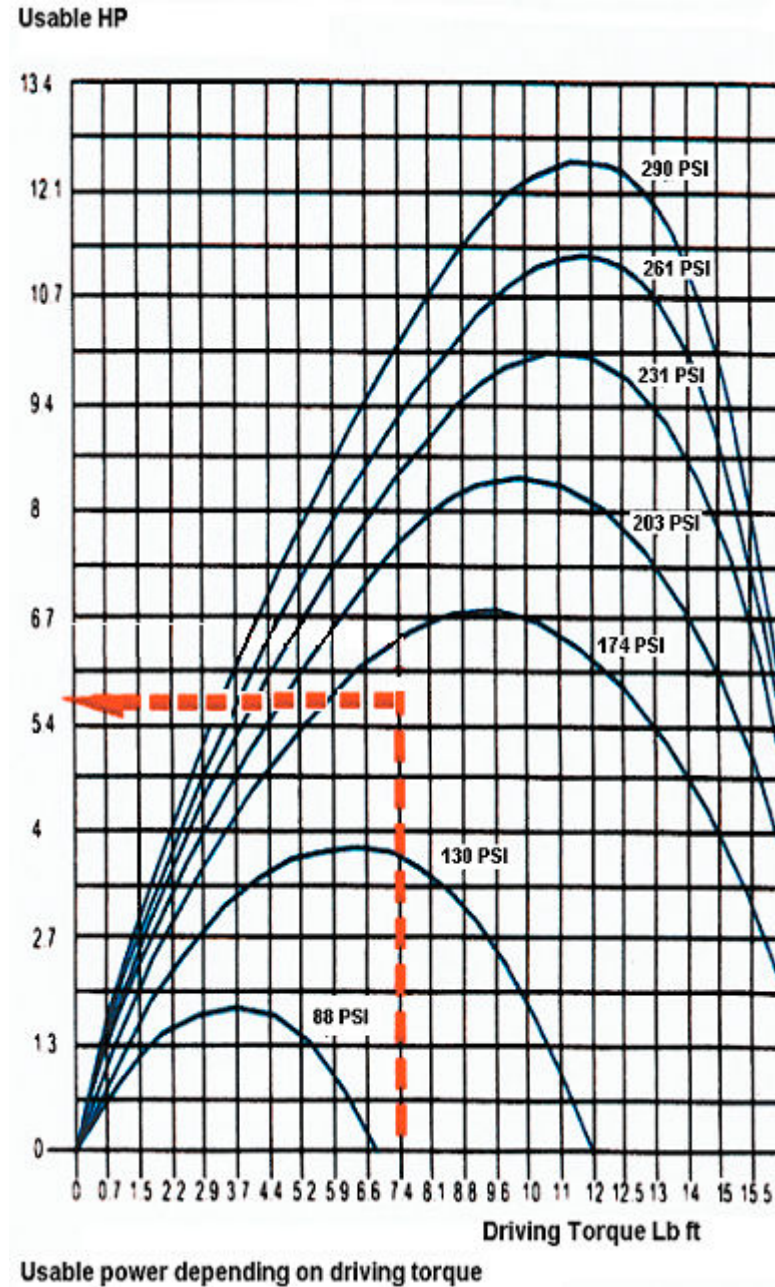

Usable power depending on driving torque

6. Inlet and Discharge Position

As delivered, the standard position of the inlet and discharge connections on your 718WT allow for easier connection of water supply lines. This positioning does not allow full range of tilt positions.

If your application requires the use of the two back tilt positions the inlet and discharge blocks on the water turbine motor may be rotated 90 degrees.

Using a 3mm hex key (not supplied) remove the 4 screws on the block, turning the block to the desired location, reinstalling the 4 screws. Use care to assure the o-ring is in place for proper seal. Torque screws to 3 lbs./in (.33 N-m), check for leaks, re-torque as required.

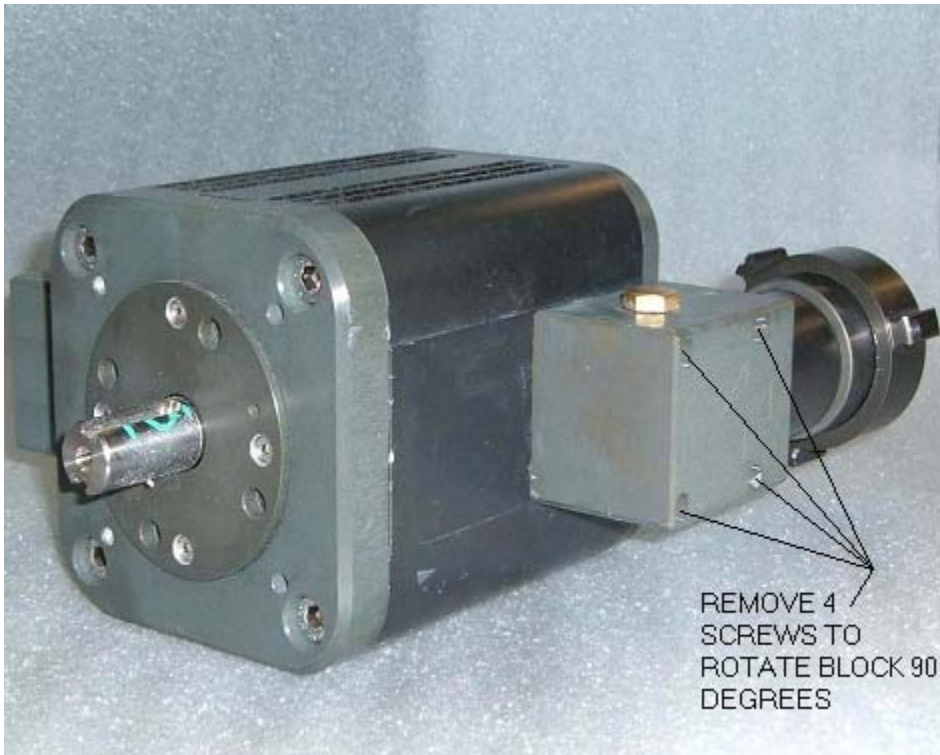

STANDARD POSITION



ROTATED POSITION

8. Exploded View Drawing

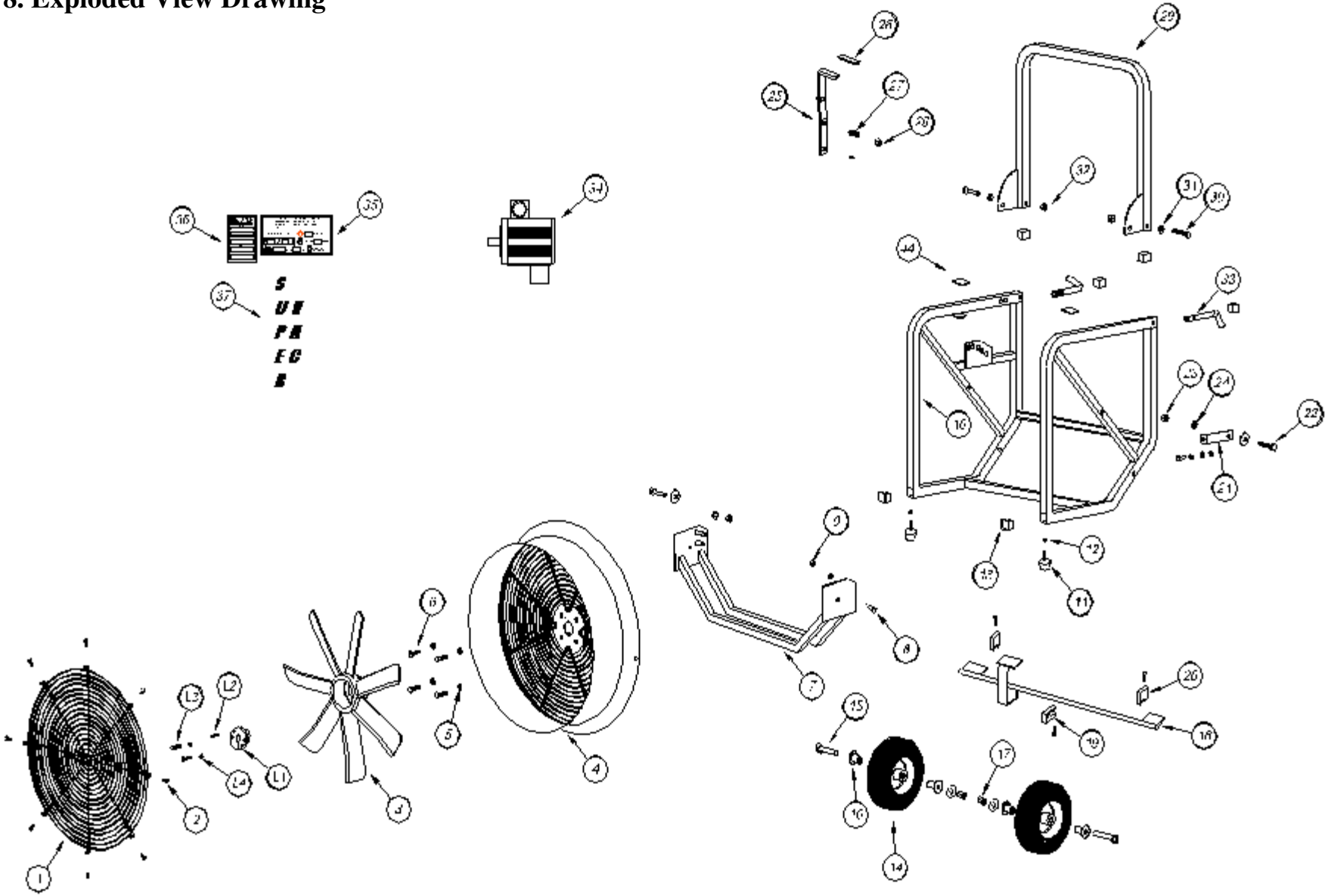

9. Warranty

Limited Warranty Five Years

Super Vacuum Manufacturing Company warrants that the equipment is free from defects in materials and workmanship when used and operated for a period of five years. The responsibility of Super Vacuum Manufacturing Company under this limited warranty is limited to the repair and replacement of any parts which are found defective and which are returned to Super Vacuum Manufacturing Company at 3842 Redman Dr, Fort Collins, CO 80524 with transportation charges prepaid (C.O.D. shipments will not be accepted).

Prior to returning defective parts to SUPER VACUUM MANUFACTURING COMPANY, the original purchaser shall make a claim in writing to SUPER VACUUM MANUFACTURING COMPANY at the above address indicating the model number and type of defect. No parts or equipment will be received by SUPER VACUUM MANUFACTURING COMPANY for repair or replacement under this warranty without specific written authority from it in advance.

Any parts damaged by improper installation, overloading, abuse or accident of any type or cause are not covered by this warranty.

All equipment manufactured by us is pre-run and tested before leaving our plant, and is shipped in good working order and condition. We therefore extend to the original purchasers the following Limited Warranty for the period of five years from the original date of purchase:

1. This warranty does not apply to defects caused by accident, misuse, neglect, or wear and tear, nor can we be held responsible for incidental and consequential expense and loss, nor does this warranty apply to equipment where alterations have been executed without our knowledge or consent. These conditions are readily discernable when the equipment is returned to us for inspection.
2. On all component parts not manufactured by SUPER VACUUM MANUFACTURING COMPANY, their warranty is to the extent that the manufacturer of such component warrants them to SUPER VACUUM MANUFACTURING COMPANY, if at all. Look in your local business phone directory for the nearest repair station for the brand of parts you have or write to us for the address.
3. If equipment received is found to have been damaged in transit, a claim should be made against the carrier within three days, as we assume no responsibility for such damage.
4. Any service other than our Authorized Service voids this warranty.
5. This warranty is in lieu of and is intended to exclude all other warranties, express or implied, oral or written, including any warranties of MERCHANTIBILITY or FITNESS for a particular purpose.

10. Contact Information

For parts or service information, contact:

Super Vacuum Manufacturing Company, Inc.
3842 Redman D
Fort Collins, CO 80524

Phone: 1-800-525-5224
970-297-7100
FAX: 970-297-7099
Internet: www.supervac.com



SUPER VAC
THE VENTILATION SPECIALISTS