

READ THIS FIRST

VENTILATOR USER GUIDE

MODEL V16-BK-WH

SUPERVAC 



PERSONAL RESPONSIBILITY CODE

The member companies of FEMSA that provide emergency response equipment and services want responders to know and understand the following:

1. Firefighting and Emergency Response are inherently dangerous activities requiring proper training in their hazards and the use of extreme caution at all times.
2. It is your responsibility to read and understand any user's instructions, including purpose and limitations, provided with any piece of equipment you may be called upon to use.
3. It is your responsibility to know that you have been properly trained in Firefighting and/or Emergency Response and in the use, precautions, and care of any equipment you may be called upon to use.
4. It is your responsibility to be in proper physical condition and to maintain the personal skill level required to operate any equipment you may be called upon to use.
5. It is your responsibility to know that your equipment is in operable condition and has been maintained in accordance with the manufacturer's instructions.
6. Failure to follow these guidelines may result in death, burns or other severe injury.



Fire and Emergency Manufacturers and Services Association, Inc.
P.O. Box 147, Lynnfield, MA 01940 www.FEMSA.org

Copyright 2006 FEMSA. All Rights Reserved

USER GUIDE

This manual covers the description, cautions, operation, and maintenance of the Super Vac V16-BK-WH.

 **WARNING** Read this manual before operating the ventilator.

Save this guide for future reference.

CONTENTS

1.	BREAKAGE OR DAMAGE DURING SHIPMENT	2
2.	GENERAL DESCRIPTION AND SPECIFICATIONS.....	3
3.	PRODUCT SAFETY PRECAUTIONS	3
4.	BEFORE OPERATING VENTILATOR	4
5.	OPERATION	5
6.	CHARGING THE BATTERY PACKS.....	6
7.	MAINTENANCE AND REPAIR.....	6
8.	WARRANTY.....	7
9.	CONTACT INFORMATION.....	8
10.	PARTS AND EXPLODED VIEWS	9-13
	FAN PARTS LIST.....	10
	FAN EXPLODED VIEW	11
	FRAME PARTS LIST	12
	FRAME EXPLODED VIEW.....	13

1. Breakage or Damage During Shipment

The transportation company is fully responsible for all shipping damage and will resolve problems promptly if you handle it correctly. Please read these instructions carefully.

Examine the contents of all shipping cases. If you find any damage, call your transportation agent at once and have them make a description on the freight or express bill describing the damage and the number of pieces. Then write us and we will send you the original bill of lading. Get a claim blank from the express or truck company. Fill the claim form out. Attach the claim blank to the original bill of lading together with a copy of our invoice. Attach a memo on which you show the value of the damaged goods. Mail or hand these papers to your local transportation agent. They will process your claim with reasonable promptness.

Please note, we cannot and will not enter claims for damages. If we filed claim here, it would be sent to your local freight agent for verification and investigation. This time can be saved by your filing the claim directly. Every consignee is on the ground floor and in contact with the local agent who inspects the damaged goods, and thus, each claim can be given individual attention.

Since our goods are packed to comply with the regulations of all railroad, truck, and express companies, we cannot allow deduction from any invoice because of any damage, however, be sure to file your claim promptly. Our goods are sold F.O.B. factory. We take receipt from the transportation company certifying that the goods were delivered to them in good order, and our responsibility ceases.

It is seldom that any breakage or damage occurs in any of our shipments, and in no case will the customer be out any expense if they follow the above instructions.

Be sure to keep all damaged goods subject to examination of the truck or express company inspector, who may call on you some time later. These damaged goods, of course, will belong to them, and they will inform you what to do with them. If you dispose of these damaged goods, your claim may not be paid.

2. General Description and Specifications

Super Vac ventilators are specifically designed to provide a convenient and portable source of air. Super Vac positive pressure ventilators are tested to AMCA Standard 240-15, for use in extreme conditions.

Model #	RPM	Motor	HxWxD	Weight
V16-BK-WH	2,000	1 HP Variable Speed DC	24.25 x 23.75" x 12.25"	51 lbs

Specifications are subject to change without notification. Refer to model decal affixed to ventilator to determine actual specifications.

This ventilator is designed for high powered air movement. Each blade is dynamically balanced for high efficiency and long life.

3. Product Safety Precautions

- Do not use the ventilator for purposes other than its' intended use.
- Wear eye and ear protection when operating the ventilator.
- Never operate ventilator while fatigued.
- Do not disassemble or modify the ventilator in any way. Doing so may lead to mechanical failure or personal injury.
- Do not wear loose clothing that could become entangled in the operating ventilator.
- Never permit anyone to operate ventilator without proper instruction.
- Do not operate ventilator without proper inlet or outlet guards in place. If guards are missing or damaged, contact factory for replacements.
- Do not place fingers or other foreign objects through inlet or outlet guards. Should a foreign object enter the ventilator, immediately stop motor. Be certain all mechanical motion has stopped. Do not use with any power voltage other than the indicated voltage.
- Never handle energized power cords with wet hands.
- Do not place or operate ventilator on unsteady tables, slanted surfaces or other unstable surfaces. Never use this ventilator in any explosive environment.
- Never let extension cords or plug connections lay in water. Locate the ventilator so that it cannot fall into water inadvertently.
- Never store or carry the battery pack so that metal objects can contact exposed battery terminals. Transporting batteries can possibly cause fires if the battery terminals contact loose nails, screws, keys, hand tools and the like.

4. Before Operating Ventilator

- This ventilator has been designed to work with either the Makita® 4.0Ah or 5.0Ah XGT® batteries.
- This ventilator will not work with any LXT batteries from Makita.

⚠ CAUTION

- A complete inspection of the ventilator should be made prior to operation.
 - Check all threaded fasteners for proper tightness.
 - Check ventilator inlet and outlet guards for obstructions. Check and remove from immediate surrounding area any objects that could be drawn into the ventilator intake.
 - Replace damaged or missing guards before operating ventilator.

⚠ CAUTION

- If using shore or mains power:
 - Never use power cords with frayed, cut, or brittle insulation.
 - Inspect power cord plug for proper connections to the ground fault interrupter circuit.

Airflow VS Setback

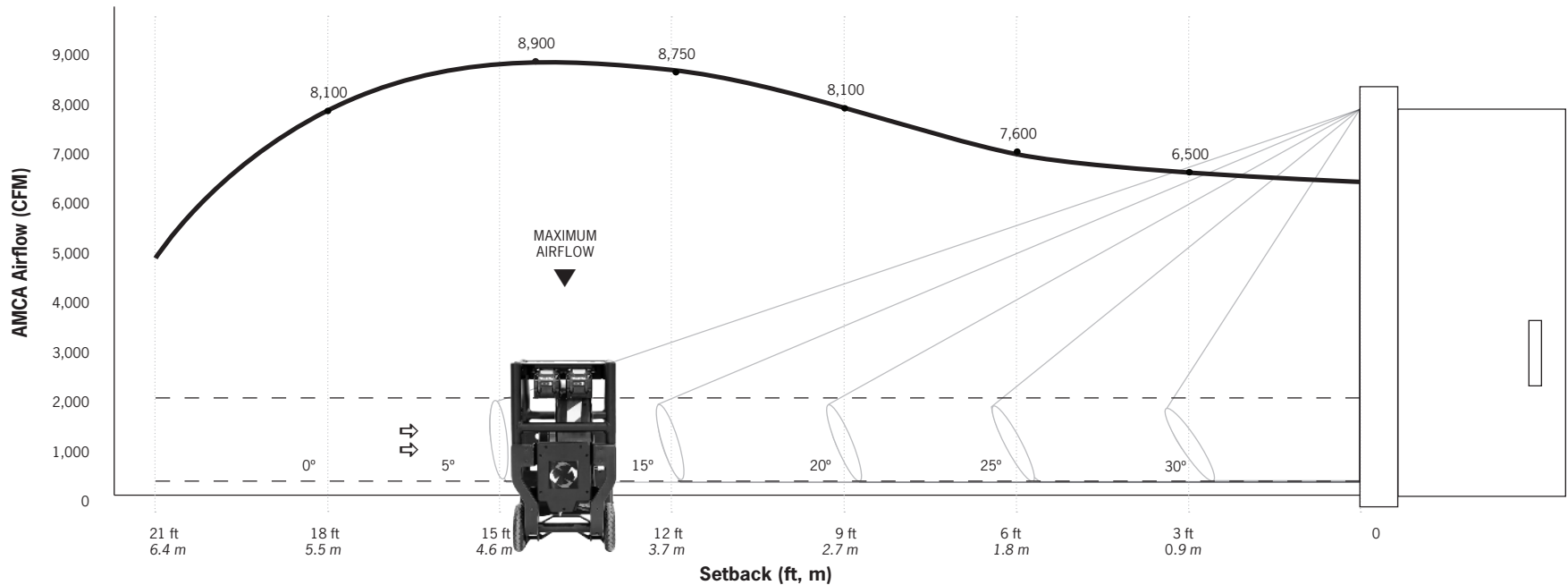

5. Operation

- **⚠ WARNING** Use caution not to direct toxic fumes into confined spaces with the ventilator.
- Insert a Makita XGT battery until it clicks. Only a single battery is necessary for operation.
- Battery removal will get easier with more remove/replace cycles. The Battery Adapter & XGT Battery interface is required by Makita.
- Fan will need to be reset (turned off & on) if a new battery is inserted.
 - If fan is not reset, then the fan will not recognize the new battery and run until previous battery is empty.
- If using shore (mains) power, use an extension cord to connect to 110 – 240V AC.
- Press and hold power button until blue backlight indicates powering up.
- When the fan is on, it will need to run at the minimum speed allowed by Makita. (This feature is to protect the batteries from small parasitic draws)
- Turn speed control clockwise until desired speed is reached.
- Power button will indicate approximate power left. (It is normal for colors to flicker back and forth if 2 batteries are being used)
 - Green: 50 - 100%
 - Yellow: 20 - 50%
 - Red: 0 - 20% (Low Battery Warning: Front Facing LED will also flash if turned on)
- To turn off, press and hold power button until blue backlight shows.

V16-BK-WH Runtimes (at Max Speed)

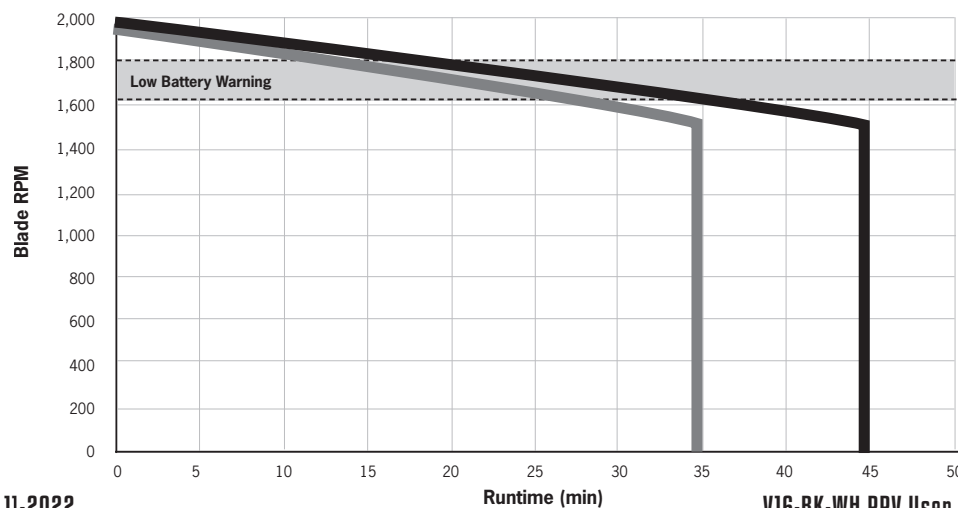

■ (2)XGT x 4.0 Ah ■ (2)XGT x 5.0 Ah

*Runtimes dependent on air density, and battery condition. Test data shown taken at 5,000 ft elevation, 25% RH, 70°F with new batteries.

*Air density is primarily affected by elevation, humidity and temperature.

*At temperatures below freezing expect battery life to decrease.

*Other XGT Batteries will operate the fan, but at reduced runtimes.

6. Charging the Battery Packs

- Remove Makita batteries from fan.
- **CAUTION** Insert in Makita Charger. Use only Makita XGT® brand battery chargers.
- When the battery pack temperature is outside the charging range (40-105°F or 5-40°C), the red light on the charger will flash and the battery will not charge.
- Once the battery pack is within the acceptable temperature range, normal charging will take place.
- Using the Makita Rapid Optimum Charger, a 4.0 Amp hour battery will recharge in 45 minutes and an 5.0 Amp hour battery will recharge in 50 minutes.
- Other Makita chargers, including units that work with vehicle DC power, may take longer to fully charge the batteries.

7. Maintenance and Repair

CAUTION Maintenance should only be performed by experienced and trained personnel. If you have any questions please contact Super Vac before attempting any maintenance at www.supervac.com or 1-800-525-5224.

WARNING Be sure the ventilator is disconnected from the power source and both batteries have been removed before performing any maintenance or repair. The motor is of heavy duty ball bearing construction. The unit is completely sealed and requires no lubrication for the life of the motor.

CAUTION The ventilator blade should be specially checked for build-up of material or dirt which may cause an imbalance. Excessive imbalance can lead to accelerated wear on motor bearings and vibration. Remove front ventilator guard. Clean blade and inside housing with mild detergent and water. Do not use abrasives, sharp instruments or caustic solvents that may scratch or damage the fan blade.

CAUTION

- Do not store battery packs or chargers above 120°F (50°C) or in direct sunlight.
- Never use/store chargers or batteries in explosive atmospheres.
- Never attempt to open the battery pack. If cracked or damaged, return it to a service center for recycling.
- Do not splash or immerse charger in water or other liquids.

8. Warranty

Makita products carry a separate 3-year limited warranty for the compatible battery packs, chargers and battery adapter. For more information contact them at www.makitatools.com or 1-800-462-5482.

Super Vacuum Manufacturing Company warrants that the equipment is free from defects in materials and workmanship when used and operated for a period of five years, excluding the motor which has a 3-year warranty. The responsibility of Super Vacuum Manufacturing Company under this limited warranty is limited to the repair and replacement of any parts which are found defective and which are returned to Super Vacuum Manufacturing Company at 3842 Redman Dr, Fort Collins, CO 80524 with transportation charges prepaid (C.O.D. shipments will not be accepted).

Prior to returning defective parts to SUPER VACUUM MANUFACTURING COMPANY, the original purchaser shall make a claim in writing to SUPER VACUUM MANUFACTURING COMPANY at the above address indicating the model number and type of defect. No parts or equipment will be received by SUPER VACUUM MANUFACTURING COMPANY for repair or replacement under this warranty without specific written authority from it in advance.

Any parts damaged by improper installation, overloading, abuse or accident of any type or cause are not covered by this warranty. All equipment manufactured by us is pre-run and tested before leaving our plant and is shipped in good working order and condition. We therefore extend to the original purchasers the following Limited Warranty for the period of five years from the original date of purchase:

1. This warranty does not apply to defects caused by accident, misuse, neglect, or wear and tear, nor can we be held responsible for incidental and consequential expense and loss, nor does this warranty apply to equipment where alterations have been executed without our knowledge or consent. These conditions are readily discernible when the equipment is returned to us for inspection.
2. On all component parts not manufactured by SUPER VACUUM MANUFACTURING COMPANY, their warranty is to the extent that the manufacturer of such component warrants them to SUPER VACUUM MANUFACTURING COMPANY, if at all. Look in your local business phone directory for the nearest repair station for the brand of parts you have or write to us for the address.
3. If equipment received is found to have been damaged in transit, a claim should be made against the carrier within three days, as we assume no responsibility for such damage.
4. Any service other than our Authorized Service voids this warranty.
5. This warranty is in lieu of and is intended to exclude all other warranties, express or implied, oral or written, including any warranties of MERCHANTABILITY or FITNESS for a particular purpose.

9. Contact Information



For parts or service information, contact:

Super Vacuum Manufacturing Company, Inc.

3842 Redman Dr.
Fort Collins, CO 80524

Phone: 800-525-5224
970-297-7100

Fax: 970-297-7099

Email : info@supervac.com
Internet: www.supervac.com

10. Parts List and Exploded Views

PARTS AND EXPLODED VIEWS

Fan Parts List

PARTS LIST							
ITEM	QTY	PART NUMBER	DESCRIPTION	ITEM	QTY	PART NUMBER	DESCRIPTION
1	1	V16-BX	V16-BX, ASSY	17	6	032-24440	WASHER, 1/4-20, SPLIT LOCK, S, ZINC
2	1	005-18010	SEAL, CONTA-CLIP- BLANK	18	1	008-14165	KEYSTOCK, MOTOR, BM, VALOR, BATTERY
3	2	005-18013	SEAL, CONTA-CLIP- 2x5MM	19	4	032-29275	SCREW, M6X1.0 ANSI M, 10mm, BHCS, SS
4	1	019-20498	WLDMNT, TOP PLATE, V16-BH	20	1	008-14166	BUSHING, MARTIN, G, 12MM BORE, VXX-BX
5	2	005-18007	BATTERY ADAPTER PLATE, V20-BH	21	1	003-15330	BLADE, PLASTIC, 30DEG, V16-BX
6	2	005-18023	SEAL, BATTERY ADAPTER, BH	22	2	032-24339	SCREW, 1/4-20 UNC X 1 in, HHCS, SS
7	2	005-18008	BATTERY ADAPTER PLATE COVER, V20-BH	23	1	012-15392	STREAMSHAPER GUARD FOR 16" PPV FAN
8	2	005-18024	SEAL, BH BATTERY ADAPTER PCB	24	4	032-22414	SCREW, 10-24 UNC X 1/2 in, PPMS, SS, BLACK, PATCH
9	2	005-18041	BATTERY ADAPTER, PCB ASM VXX-BH	25	8	032-21688	SCREW, 8-32 UNC X 5/16, PPMS, SS, BLACK, PATCH
10	4	032-22617	SCREW, 10-24 UNC X 3/8 in, SHCS, SS, BLACK	26	1	005-15356	POWER SUPPLY, 750W, 27V, V1X-BX
11	4	032-22622	SCREW, 10-24 UNC X 1 in, SHCS, SS, BLACK	27	1	025-16020	DECAL, SHROUD, CENTER, V1X-BX
12	1	019-20465	SHROUD, WELDMENT, BM V16-BX	28	1	025-16042	DECAL, SHROUD, CHEVRON, V1X-BX
13	1	021-10531	MOTOR, 28VDC, VALOR SERIES	29	1	025-16110	DECAL, MODEL TOP, V16-BH-WH
14	1	005-18022	MOTOR PLATE GASKET, V20-BX	30	1	025-16111	DECAL, SERIAL NUMBER, V16-BH-WH
15	1	019-20533	PLATE COVER MOTOR, V20-BX	31	1	005-18027	SHROUD SLEEVE SEAL SPLIT ALT, BAU
16	4	032-26260	SCREW, M3X0.5 ANSI M, 6mm, PPMS, SS, BLACK	32	8	032-20151	SCREW, 4-40 UNC X 1/4 in, PPMS, SS, BLACK

Fan Exploded View

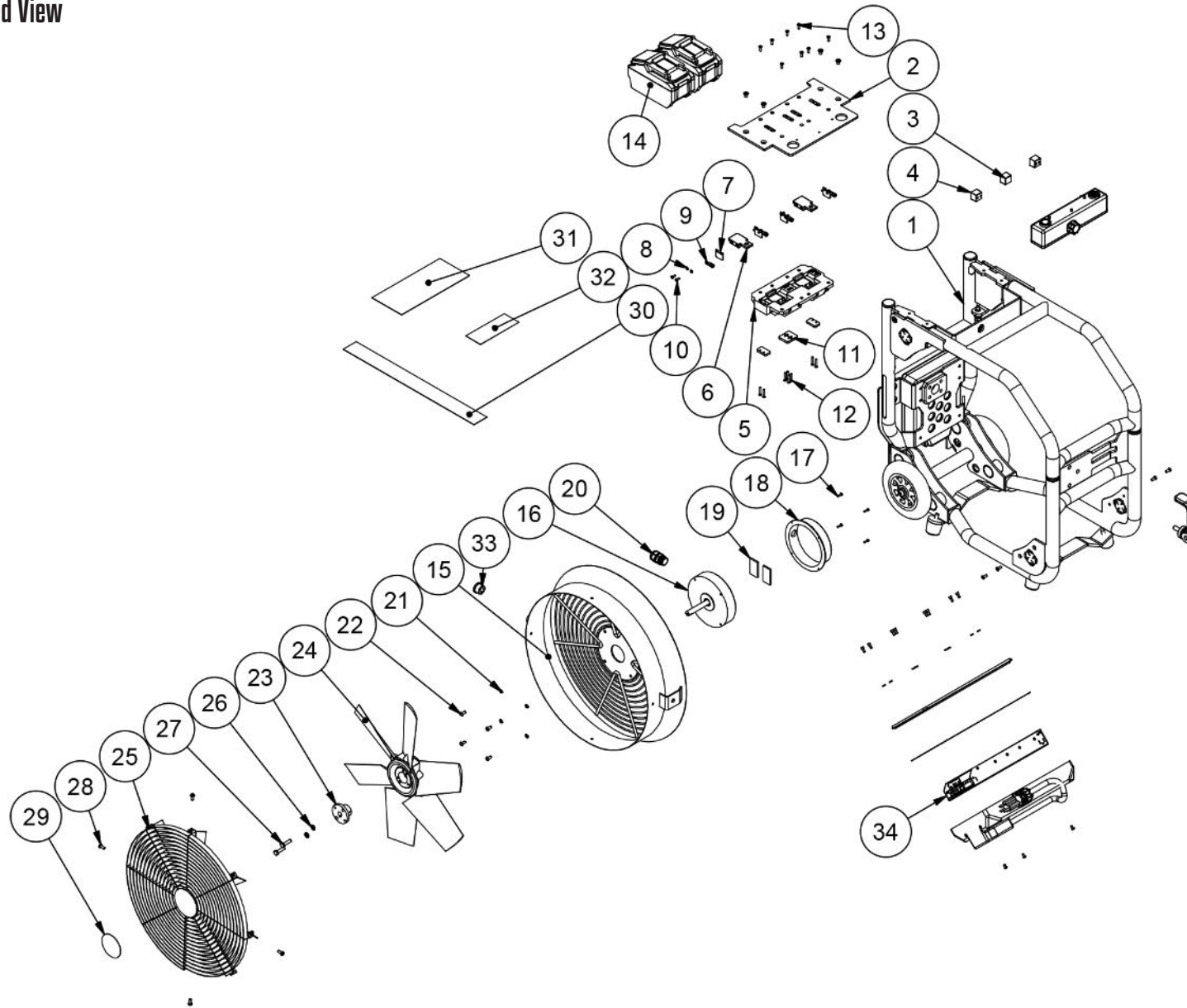

Frame Parts List

PARTS LIST				PARTS LIST			
ITEM	QTY	PART NUMBER	DESCRIPTION	ITEM	QTY	PART NUMBER	DESCRIPTION
1	2	005-10270	WASHER, RUBBER, ROTATION, V1X-BX	33	2	005-18010	SEAL, CONTA-CLIP- BLANK
2	1	005-18005	BOX POWER SUPPLY, VXX-BX	34	1	005-18014	SEAL, CONTA-CLIP - 10MM
3	1	005-18020	BOX POWER SUPPLY GASKET, V20-BX	35	1	005-10180	CORD, POWER SUPPLY, 120VAC, 24 IN.
4	1	005-18006	BOX POWER SUPPLY COVER, V20-BX	36	2	005-18015	SEAL, CONTA-CLIP - 13-14 mm
5	2	008-13804	WHEEL, V1X-BX, 6 INCH	37	2	005-18017	SEAL, CONTA-CLIP - 9-10 mm
6	4	024-13473	FEET RUBBER CONE SHAPE VBM-4002	38	6	032-22618	SCREW, 10-24 UNC X 1/2 in, SHCS, SS, BLACK
7	1	019-20509	TUBE WHEEL SPACER, V20-BX	39	6	032-22980	O-RING, 10-24 UNC, HARDWARE BUNA
8	2	012-14196	INSERT, 3/8-16, TUBE, V1X-BX AXLE MOUNT	40	25	032-22249	O-RING, 8-32 UNC, HARDWARE BUNA
9	6	005-10256	PLUG, 1.25, TUBE END ROUND, VALOR	41	21	032-21886	SCREW, 8-32 UNC X 3/8 in, SHCS, SS, BLACK
10	1	005-18002	BOX CONTROLLER COVER, VXX-BX	42	4	032-21888	SCREW, 8-32 UNC X 5/8 in, SHCS, SS, BLACK
11	1	005-10255	T-HANDLE, PLUNGER, VALOR	43	6	032-22482	SCREW, 10-24 UNC X 1/2 in, PFMS, SS, BLACK
13	1	008-14131	PLASTIC, PAC CORD CLAMP	44	2	032-22414	SCREW, 10-24 UNC X 1/2 in, PPMS, SS, BLACK, PATCH
14	1	005-10268	VALOR, POTENTIOMETER, VXX-BX	45	3	032-22821	SCREW, 10-24 UNC X 3/8 in, BHCS, SS, BLACK, PATCH
15	1	005-13562	SWITCH, MOMENTARY, RGB, V1X-BX	46	4	032-22550	SCREW, 10-24 UNC X 1/2 in, PFMS, SS, BLACK, PATCH
16	1	005-13564	SWITCH, LATCHING, V1X-BX	47	2	032-24486	SCREW, 5/16-18 UNC X 1 in, PFMS, SS, BLACK
17	1	005-10267	KNOB, POTENTIOMETER, V1X-BX	48	2	032-10789	NUT, NYLOCK, 5/16-18 UNC, SS
18	2	STD HARDWARE-BHSH-713	STD HARDWARE-BHSH-713, 3/8-16x2-1/2, S	49	1	034-11073	NUT, NYLOCK, 3/8-16 UNC, SS
19	4	032-10140	INSERT, BRASS HEAT SET, 4/40	50	3	032-27672	SCREW, M4X0.7 ANSI M, 8mm, BHCS, SS, BLACK, PATCH
22	1	005-18001	BOX CONTROLLER, VXX-BX	51	4	032-24011	SCREW, 1/4-20 UNC X 3/8 in, PFMS, SS, BLACK, PATCH
23	1	005-18050	PLASTIC SLEEVE MOUNT, V16-BX	52	2	032-22982	NUT, 10-24 UNC, INSERT, .13-.225 GRIP RANGE
24	1	005-18053	PLASTIC, SLEEVE LOCK, VXX-BX	53	6	032-10880	NUTSERT, 10-24, .02-.13 GRIP RANGE
25	1	021-10514	CONTROLLER, HG, 18V / 36V DC MOTOR	54	4	032-20134	SCREW, 4-40 UNC X 1/4 in, PPMS, SS
26	27	032-10142	INSERT, BRASS HEAT SET, 8/32	55	1	019-20499	FRAME WLDMENT, V16X-BX
27	1	005-18021	BOX CONTROLLER GASKET, VXX-BX	56	1	019-20462	WLDMNT HANDLE, V16X-BL
28	1	005-18003	BOX TOP ELECTRIC, VXX_BX	57	2	032-21682	SCREW, 8-32 UNC X 3/8 in, PPMS, SS, BLACK, PATCH
29	1	005-18004	BOX TOP ELECTRIC COVER, VXX-BX	58	1	005-13563	LIGHT, LED, V1X-BX
30	4	032-10143	INSERT, BRASS HEAT SET, 10/24	59	2	005-10271	GROMMET, PUSH-IN, 0.75 ID, 1.125 OD, 0.0938 GROOVE
31	2	019-20455	PLASTIC STAIR SKID, V16X-BX	60	1	025-16032	DECAL, SV LOGO, SIDE, VXX-FX
32	2	032-10120	WASHER, PLASTIC, 5/16	61	1	019-20551	HANDLE, CAM LOCK ASSY, VXX_BX

Frame Exploded View

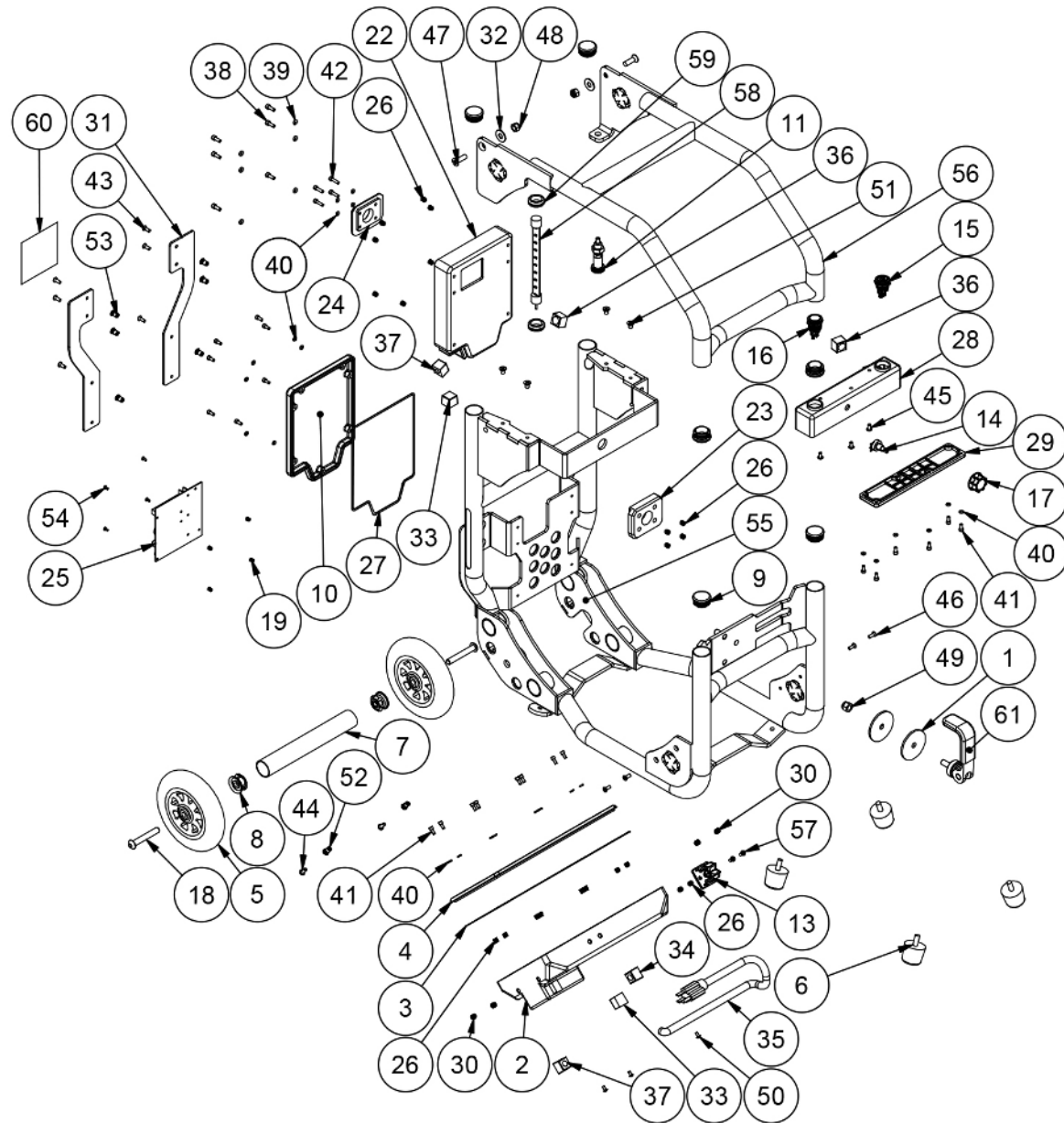

V16-BX-WH