

Spare Parts List  
Ersatzteilliste  
Liste de pièces détachées  
Lista de piezas de repuesto

2014-06

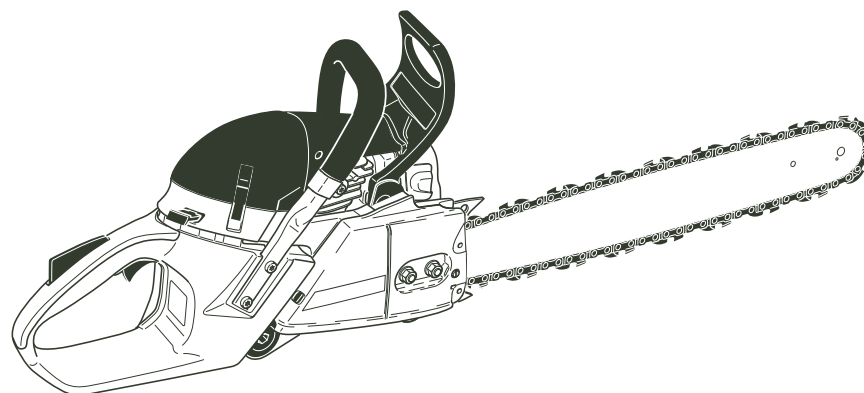

PS-7310  
PS-7310 H  
PS-7910  
PS-7910 H  
PS-7310 (USA,CDN)  
PS-7310 H (USA,CDN)  
PS-7910 (USA,CDN)  
PS-7910 H (USA,CDN)

**DOLMAR**



A member of the *Makita* Group

995700088 (D, GB, F, E)

PS-7310, PS-7310 H, PS-7910,  
PS-7910 H, PS-7310 , PS-7310  
H , PS-7910 , PS-7910 H

1

Kraftstofftank, Bügelgriff  
Fuel tank, tubular grip  
Réserv. carburant, poignée tubulaire  
Depósito de combustible, mango tubular

**DOLMAR**  
A member of the **Trakita** Group

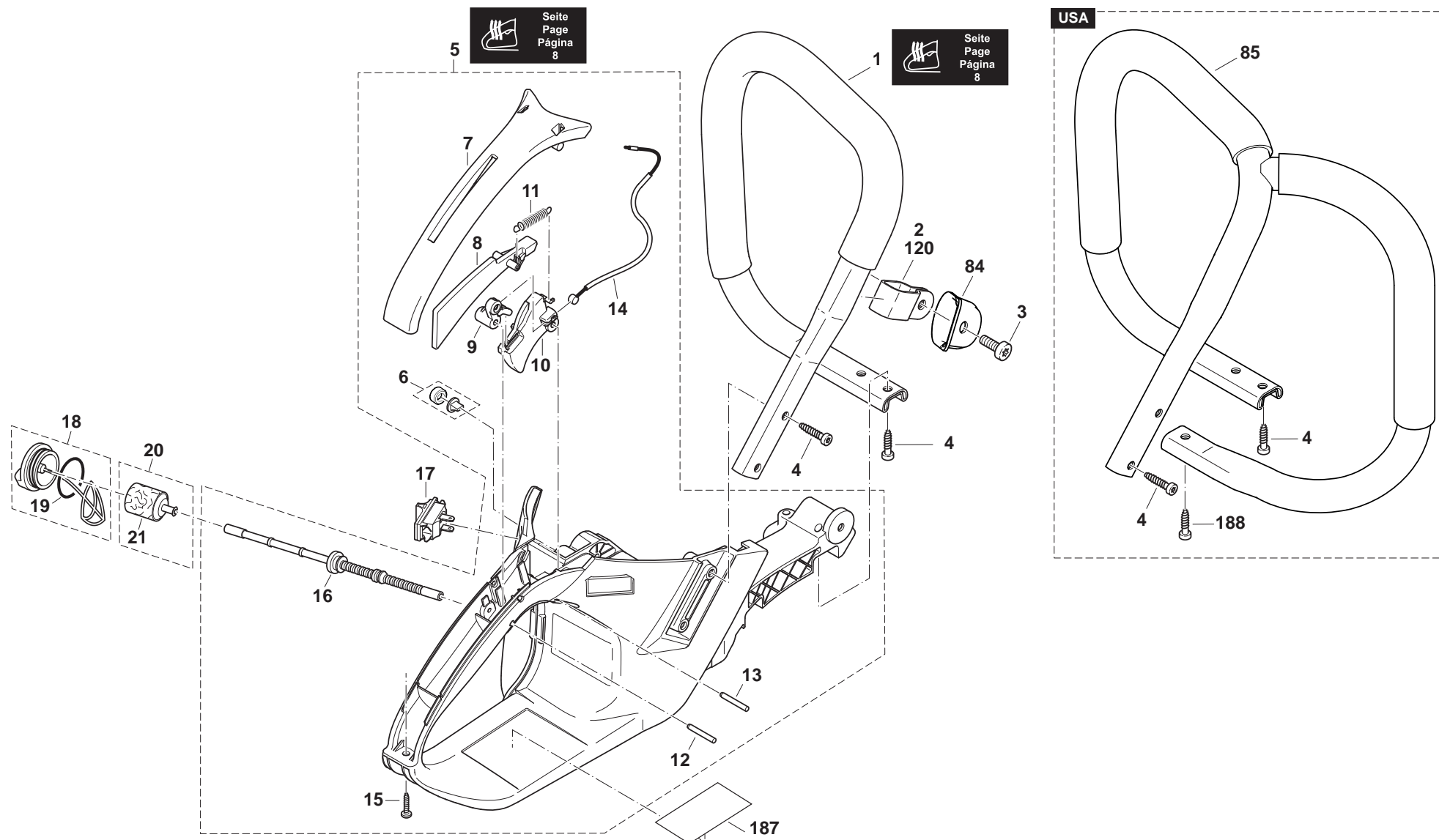

PS-7310, PS-7310 H, PS-7910,  
PS-7910 H, PS-7310 , PS-7310  
H , PS-7910 , PS-7910 H

1

Kraftstofftank, Bügelgriff  
Fuel tank, tubular grip  
Réserv. carburant, poignée tubulaire  
Depósito de combustible, mango tubular

**DOLMAR**  
A member of the **Takita** Group

Seite / Page	Pos.	PS-7310	PS-7310 H	PS-7910	PS-7910 H	PS-7910 (USA,CDN)	PS-7910 H (USA,CDN)	PS-7910 (USA,CDN)	PS-7910 H (USA,CDN)	Teil-Nr. Part No. No. de pièce No. de pieza	Hinweise Notes Renseign. Nota	Bezeichnung	Spezifikation Specification	Description	Désignation	Denominación
1	1	1	1	1	1	1	1	1	1	038 310 020		BÜGELGRIFF KPL.		TUBULAR HANDLE ASSY.	POIGNÉE TUBULAIRE CPL.	MANGO TUBULAR CPL.
1	2	1	1	1	1	1	1	1	1	038 310 062		SCHELLE		CLAMP	BRIDE DE FIXATION	ABRAZADERA
1	3	1	1	1	1	1	1	1	1	908 006 145		SCHRAUBE	M6x14	SCREW	VIS	TORNILLO
1	4	4	4	4	4	4	4	4	4	913 455 164		INNENSTERN SCHRAUBE	5,5X16	SCREW	VIS	TORNILLO
1	5	1		1		1		1		038 114 270		KRAFTSTOFFTANK KPL. ROT		FUEL TANK CPL. RED	RÉSERVOIR CPL. ROUGE	DEPÓSITO CPL. ROJO
1	5					1		1		038 114 200		KRAFTSTOFFTANK KPL. ROT	USA (EPA)	TANK CPL. RED	RÉSERVOIR CPL. ROUGE	DEPÓSITO CPL. ROJO
1	6	1	1	1	1	1	1	1	1	957 114 061		BELÜFTUNGSVENTIL KPL.		AIR VALVE CPL.	SOUPAPE D'AERATION CPL.	VÁLVULA VENTILACION CPL.
1	8	1	1	1	1	1	1	1	1	038 117 020		SICHERHEITSSPERRTASTE		CATCH LEVER	LEVIER DE VERROUILLAGE	PALANCA TRINCADA
1	7	1	1	1	1	1	1	1	1	038 114 031		HANDSCHALE ROT		GRIP PLATE RED	PLAQUE DE POIGNÉE ROUGE	CAPA DE MANGO ROJO
1	9	1	1	1	1	1	1	1	1	038 117 030		UMLENKHEBEL		ROCKER	LEVIER DE RENVOI	PALANCA DE CAMBIO
1	10	1	1	1	1	1	1	1	1	038 117 010		GASHEBEL		THROTTLE LEVER	LEVIER D' ACCÉLÉRATION	ACELERADOR
1	11	1	1	1	1	1	1	1	1	038 117 050		ZUGFEDER		SPRING	RESSORT	RESORTE
1	12	1	1	1	1	1	1	1	1	935 930 240		ZYLINDERSTIFT	3x24	CYLINDRICAL PIN	GOUPILLE CYL.	PRISIONERO
1	14	1	1	1	1	1	1	1	1	038 117 041		BOWDENZUG KPL.		BOWDEN CABLE	CÂBLE DE COMMANDE	TRANSMIS. FLEXIBLE BOWDEN
1	13	1	1	1	1	1	1	1	1	935 930 280		ZYLINDERSTIFT	ø3x28	CYLINDRICAL PIN	GOUPILLE CYLINDRIQUE	PRISIONERO
1	15	1	1	1	1	1	1	1	1	913 340 204		INNENSTERN-SCHLITZ SCHRAUBE		SCREW	VIS	TORNILLO
1	16	1	1	1	1	1	1	1	1	038 114 052		KRAFTSTOFFLEITUNG	EPA code	FUEL LINE	CONDUITE CARBURANT	CONDUCTO COMBUSTIBLE
1	17	1	1	1	1	1	1	1	1	975 001 241		KURZSCHLUßSCHALTER		SHORT-CIRCUIT SWITCH	INTERRUPTEUR COURT-CIRCUIT	INTERRUPTOR CORTO CIRCUITE
1	18	1	1	1	1	1	1	1	1	010 114 050		TANKVERSCHLUß KPL. (KRAFTST.)		TANK CAP ASSY. (FUEL)	BOUCHON RÉSERV. CPL. (CARB.)	CIERRE DE DEPÓSITO CPL.
1	19	1	1	1	1	1	1	1	1	963 228 030		O-RING	ø 28x3	PACKING RING	BAGUE-JOINT	ANILLO DE GUARNICIÓN
1	20	1	1	1	1	1	1	1	1	010 114 010		SAUGKOPF KPL.		SUCTION HEAD	TÊTE D'ASPIRATION	CABEZA DE ASPIRACION
1	21	1	1	1	1	1	1	1	1	010 114 020		REPARATUR-SATZ, FILTER (JE 5 STCK.)	for 010114010	REP. KIT, FILTER (5 OF EACH)	JEU DE RÉPARAT., FILTRE	JUEGO DE REPARAR, FILTRO
1	84	1	1	1	1	1	1	1	1	038 310 070		FEDERANSCHLAG		SPRING LIMITER	RESSORT DE BUTEE	MUELLE DE TOPE
1	85					1		1		038 310 111		RUNDUMBÜGELGRIFF KPL.	USA	WRAP AROUND HANDLE ASSY.	POIGNÉE CIRCULAIRE CPL.	MANGO CIRCULAR CPL.
1	120	1	1	1	1	1	1	1	1	010 114 039		FEDERN SATZ		SET OF SPRINGS	JEU DE RESSORTS	JUEGO DE RESORTES
1	187					1	1	1	1			AUFKLEBER TANK	USA - EVAPORATION DOLMAR	LABEL, TANK	PLAQUE, RÉSERVOIR	CALCOMANIA, DEPÓSITO
1	188					1	1	1	1	913 455 164		INNENSTERN SCHRAUBE	5,5X16	SCREW	VIS	TORNILLO

PS-7310, PS-7310 H, PS-7910,  
PS-7910 H, PS-7310 , PS-7310  
H , PS-7910 , PS-7910 H

2

Abdeckhaube, Luftfilter, Schalldämpfer  
Hood, air filter, muffler  
Capot protecteur, filtre à air, pot d'échappement  
Cubierta protectora, filtro de aire, silencioso

**DOLMAR**



A member of the **Trakita** Group

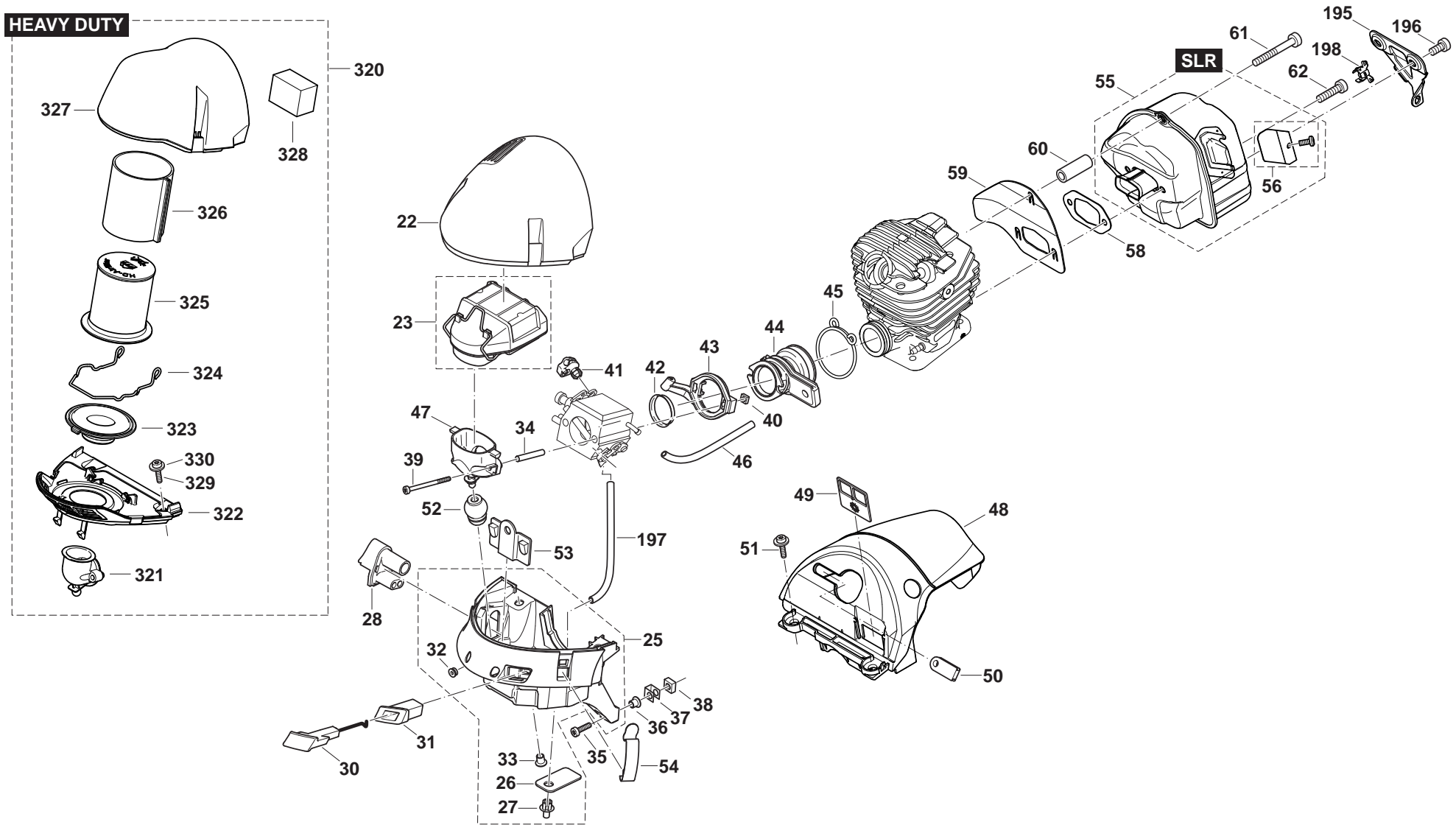

PS-7310, PS-7310 H, PS-7910,  
PS-7910 H, PS-7310 , PS-7310  
H , PS-7910 , PS-7910 H

2

Abdeckhaube, Luftfilter, Schalldämpfer  
Hood, air filter, muffler  
Capot protecteur, filtre à air, pot d'échappement  
Cubierta protectora, filtro de aire, silencioso

**DOLMAR**  
A member of the **Takita** Group

Seite / Page	Pos.	PS-7310	PS-7310 H	PS-7910	PS-7910 H	PS-7910 (USA, CDN)	PS-7310 H (USA, CDN)	PS-7910 (USA, CDN)	PS-7910 H (USA, CDN)	Teil-Nr. Part No. No. de pièce No. de pieza	Hinweise Notes Renseign. Nota	Bezeichnung	Spezifikation Specification	Description	Désignation	Denominación
2	22	1	1	1	1	1	1	1	1	038 118 024		DECKEL SCHWARZ MATT		COVER BLACK	CAPOT NOIR	CUBIERTA NEGRO
2	23	1	1	1	1	1	1	1	1	038 173 101		LUFTFILTER KPL.	VLIES	AIR FILTER CPL.	FILTRE À AIR CPL.	FILTRO DE AIRE CPL.
2	23	1	1	1	1	1	1	1	1	038 173 011		LUFTFILTER KPL.	NYLON	AIR FILTER CPL.	FILTRE À AIR CPL.	FILTRO DE AIRE CPL.
2	23	1	1	1	1					038 173 080	IT, PT	LUFTFILTER KPL.	NYLON 0,05 MM	AIR FILTER CPL.	FILTRE À AIR CPL.	FILTRO DE AIRE CPL.
2	25	1	1	1	1	1	1	1	1	038 118 170		BODEN ROT		BOTTOM RED	FOND ROUGE	FONDO ROJO
2	26	2	2	2	2	2	2	2	2	038 118 110		GUMMIKLAPPE		RUBBER FLAP	CLAPET CAOUTCHOUC	VÁLVULA DE GOMA
2	27	2	2	2	2	2	2	2	2	938 650 062		SPREIZNIET		RIVET	RIVET	REMACHE
2	28	1	1	1	1	1	1	1	1	038 118 085		FÜHRUNG		GUIDE	GUIDAGE	GUÍA
2	30	1	1	1	1	1	1	1	1	038 155 052		CHOKESTANGE		CHOKE SHAFT	LEVIER DE STARTER	PALANCA ESTRANGUL. AIRE
2	31	1	1	1	1	1	1	1	1	038 155 020		CHOKEFÜHRUNG		CHOKE GUIDE	GAINÉ STARTER	GUÍA DEL STARTER
2	32	1	1	1	1	1	1	1	1	038 118 300		GUMMITÜLLE		RUBBER BUSH	GAINÉ CAOUTCHOUC	BOQUILLA DE CAUCHO
2	33	2	2	2	2	2	2	2	2	001 118 100		BUCHSE		BUSHING	DOUILLE	CASQUILLO
2	34	2	2	2	2	2	2	2	2	038 155 060		DISTANZROHR	30 mm	SPACER	DOUILLE DE DISTANCE	CASQUILLO SEPARADOR
2	35	2	2	2	2	2	2	2	2	908 005 205		INNENSTERN SCHRAUBE	M5x20	SCREW	VIS	TORNILLO
2	36	2	2	2	2	2	2	2	2	001 118 100		BUCHSE		BUSHING	DOUILLE	CASQUILLO
2	37	2	2	2	2	2	2	2	2	038 111 050		KLAMMER		CLIP	AGRAFE	GRAPA
2	38	2	2	2	2	2	2	2	2	038 111 060		4KT-MUTTER	M5, SW10	SQUARE NUT	ECROU CARRÉ	TUERCA CUADR.
2	39	2	2	2	2	2	2	2	2	908 204 555		INNENSTERN-SCHRAUBE	M4x55	SCREW	VIS	TORNILLO
2	40	2	2	2	2	2	2	2	2	921 804 004		4KT-MUTTER	M4	SQUARE NUT	ECROU CARRÉ	TUERCA CUADR.
2	41	1	1	1	1	1	1	1	1	038 155 012		AUFNAHME FÜR BOWDENZUG		RETAINING CLIP	SUPPORT DU DISPOS. DE TIRAGE	TRACCIÓN BOWDEN, SOPORTE
2	42	1	1	1	1	1	1	1	1	038 131 031		EINSATZ FÜR ANSAUGSCHLAUCH		INSERT FOR SUCTION HOSE	PIÈCE P. TUYAU D'ASPIRATION	SUPLEMENTO P. TUBO DE ASP.
2	43	1	1	1	1	1	1	1	1	038 171 041		FLANSCHRING		FLANGE	BRIDE	BRIDA
2	44	1	1	1	1	1	1	1	1	038 131 011		ANSAUGSCHLAUCH		SUCTION HOSE	TUYAU D'ASPIRATION	TUBO DE ASPIRACIÓN
2	45	1	1	1	1	1	1	1	1	038 131 070		FEDERSCHELLE		HOSE CLIP	COLLIER DE SERRAGE	ABRAZADERA
2	46	m	m	m	m	m	m	m	m	965 452 382		SCHLAUCH	75 mm	TUBE	GAINÉ	TUBO
2	47	1	1	1	1	1	1	1	1	038 171 012		ANSAUGKRÜMMER		CONNECTING MUFF	MANCHON DE JONCTION	MANGUITO DE CONEXIÓN
2	48	1	1	1	1	1	1	1	1	038 118 050		ABDECKHAUBE SCHWARZ	HEAD DECO	HOOD BLACK	CAPOT PROT. NOIR	TAPA PROT. NEGRO
2	49	1	1	1	1	1	1	1	1	038 118 140		EINSATZ SOMMER / WINTER		INSERT	PIÈCE D'INSERTION	PIEZA DE CIERRE
2	50	1	1	1	1	1	1	1	1	038 118 130		KABELDURCHFÜHRUNG		CABLE GUIDE	PASSAGE DU CÂBLE	BOQUILLA DE PASO PARA CABLES
2	51	2	2	2	2	2	2	2	2	917 105 205		INNENSTERN-KOMBISCHRAUBE	M5X20	SCREW	VIS	TORNILLO
2	52	1	1	1	1	1	1	1	1	038 171 031		HALTERUNG FÜR ANSAUGKRÜMMER		HOLDER	SUPPORT	SOPORTE
2	53	1	1	1	1	1	1	1	1	038 118 100		STOPFEN		PLUG	OBTURATION	TAPABOCADOS
2	54	2	2	2	2	2	2	2	2	130 118 070		STAHLKLAMMER		STEELCLIP	AGRAFE	PINZA DE ACERO
2	55	1	1	1	1	1	1	1	1	038 174 700		SCHALLDÄMPFER	SLR	MUFFLER	POT D'ÉCHAPPEMENT	SILENCIADOR
2	56	1	1	1	1	1	1	1	1	038 174 920		FUNKENSCHUTZSIEB KPL.		SPARK ARRESTER SCREEN CPL.	TAMIS CPL.	TAMIZ CPL.

PS-7310, PS-7310 H, PS-7910,  
PS-7910 H, PS-7310 , PS-7310  
H , PS-7910 , PS-7910 H

2

Abdeckhaube, Luftfilter, Schalldämpfer  
Hood, air filter, muffler  
Capot protecteur, filtre à air, pot d'échappement  
Cubierta protectora, filtro de aire, silencioso

**DOLMAR**  
A member of the *Trakita* Group

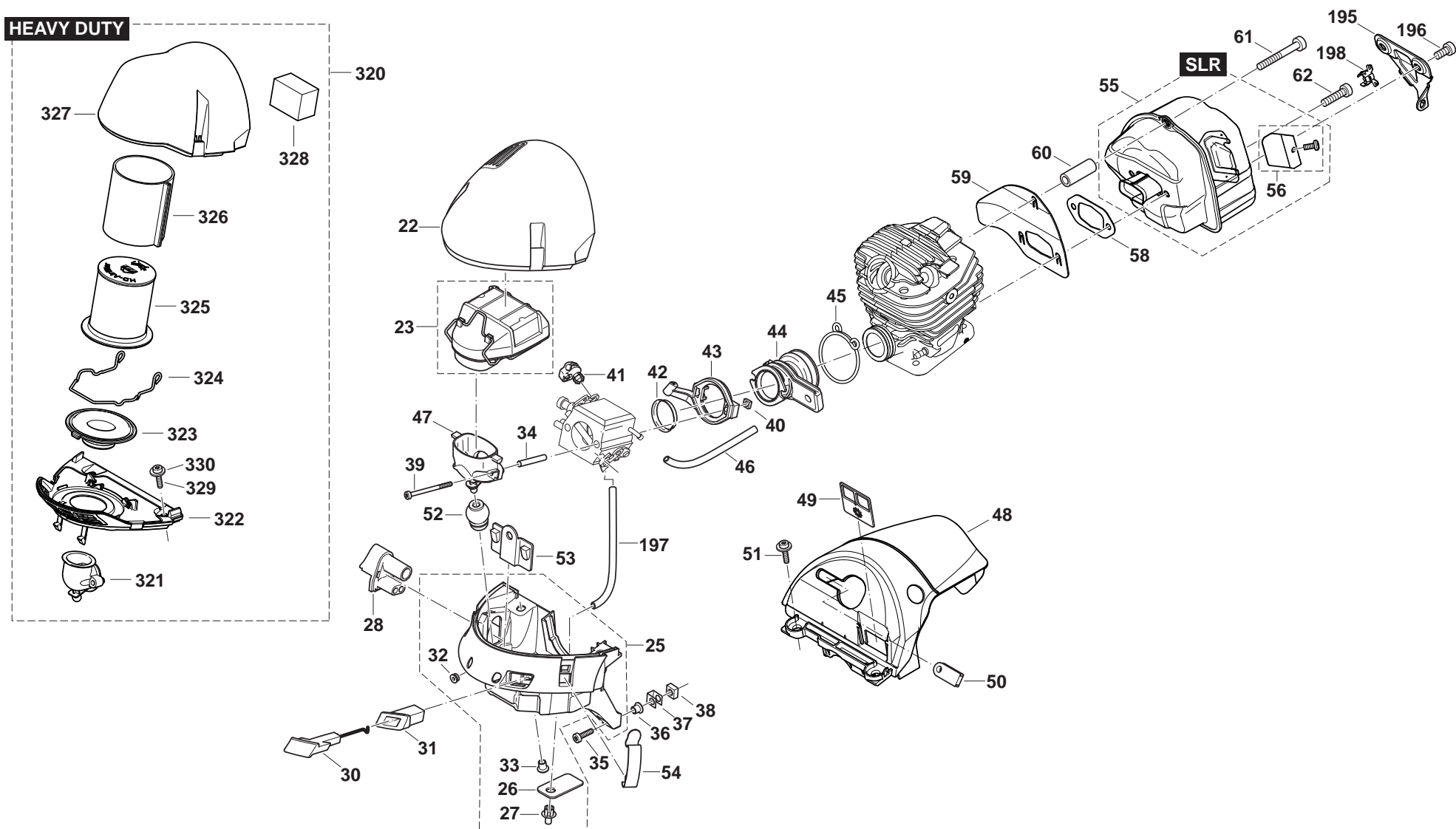

PS-7310, PS-7310 H, PS-7910,  
PS-7910 H, PS-7310 , PS-7310  
H , PS-7910 , PS-7910 H

2

Abdeckhaube, Luftfilter, Schalldämpfer  
Hood, air filter, muffler  
Capot protecteur, filtre à air, pot d'échappement  
Cubierta protectora, filtro de aire, silencioso

**DOLMAR**  
A member of the **Takita** Group

Seite / Page	Pos.	PS-7310	PS-7310 H	PS-7910	PS-7910 H	PS-7310 (USA,CDN)	PS-7310 H (USA,CDN)	PS-7910 (USA,CDN)	PS-7910 H (USA,CDN)	Teil-Nr. Part No. No. de pièce No. de pieza	Hinweise Notes Renseign. Nota	Bezeichnung	Spezifikation Specification	Description	Désignation	Denominación
2	58	1	1	1	1	1	1	1	1	038 174 811		DICHTUNG SCHALLDÄMPFER		MUFFLER GASKET	JOINT DE POT D'ÉCHAPPEMENT	JUNTA DEL SILENCIADOR
2	59	1	1	1	1	1	1	1	1	038 174 023		ABSCHIRMBLECH		COOLING PLATE	TÔLE DE PROTECTION	CHAPA DEFLECTORA
2	60	1	1	1	1	1	1	1	1	038 174 030		ZWISCHENSTÜCK	L=26,8mm	CONNECTING LINK	INTERMEDIARE	PIEZA INTERMEDIARIA
2	61	1	1	1	1	1	1	1	1	908 305 405		SCHRAUBE INNEN6RD ZK	M5x40	H.L. SOCKET HEAD BOLT	VIS	TORNILLO
2	62	2	2	2	2	2	2	2	2	908 405 205		SCHRAUBE INNEN6RD ZK	M5x20	H.L. SOCKET HEAD BOLT	VIS	TORNILLO
2	195	1	1	1	1	1	1	1	1	038 174 400		HALTEBLECH SCHALLDÄMPFER		EXHAUST HOLDER PANEL	TÔLE DE SUPPORT D'ECHAPPEMENT	CHAPA SOPORTE DEL ESCAPE
2	196	2	2	2	2	2	2	2	2	909 005 105		SCHRAUBE	M5x10	SCREW	VIS	TORNILLO
2	197	1	1	1	1	1	1	1	1	965 452 382		SCHLAUCH	110mm	TUBE	GAINÉ	TUBO
2	198	2	2	2	2	2	2	2	2	038 174 451		STOPFEN SCHALLDÄMPFERROHR	USA, CDN, AUS, NZ	PLUG FOR MUFFLER TUBE	BOUCHON POUR TUBE SILENCIEUX	TAPÓN PARA TUBO SILENCIADOR
2	320	1	1	1	1	1	1	1	1	957 173 400	ACC.	LUFTFILTER	HEAVY DUTY	AIR FILTER	FILTRE À AIR	FILTRO DE AIRE
2	321	1	1	1	1	1	1	1	1	038 171 050	ACC.	ANSAUGKRÜMMER	HEAVY DUTY	CONNECTING MUFF	MANCHON DE JONCTION	MANGUITO DE CONEXIÓN
2	322	1	1	1	1	1	1	1	1	038 118 460	ACC.	ZWISCHENBODEN		INTERMEDIATE BOTTOM	FOND	PALIER INTERMÉDIAIRE
2	323	1	1	1	1	1	1	1	1	038 118 490	ACC.	BALG		BELLOWS	BELLOWS	PIEL
2	324	1	1	1	1	1	1	1	1	038 118 450	ACC.	BÜGELKLAMMER		CLIP FOR BOW	CRAMPON	GRAPA
2	325	1	1	1	1	1	1	1	1	038 173 310	ACC.	LUFTFILTERPATRONE		AIR-FILTER CARTRIDGE	FILTRE A AIR DE CARTOUCHE	FILTRO DE AIRE DEL CARTUCHO
2	326	1	1	1	1	1	1	1	1	038 173 350	ACC.	VORFILTERPATRONE		PRE-FILTER	PRE-FILTER	FILTRO
2	327	1	1	1	1	1	1	1	1	038 118 410	ACC.	DECKEL	BLACK, HD	COVER	COUVERCLE	TAPA
2	328	1	1	1	1	1	1	1	1	038 173 370	ACC.	VORFILTER	S/W	PRE-FILTER	PREFILTRE	PRIMER FILTRO
2	329	2	2	2	2	2	2	2	2	908 405 255	ACC.	INNENSTERN-SCHRAUBE	M5x25	SCREW	VIS	TORNILLO
2	330	2	2	2	2	2	2	2	2	924 805 310	ACC.	SCHEIBE	ø5,3/15x1	DISC	DISQUE	DISCO DE TOPE



PS-7310, PS-7310 H, PS-7910,  
PS-7910 H, PS-7310 , PS-7310  
H , PS-7910 , PS-7910 H

3

Zylinder, Kurbelgehäuse  
Cylinder, crankcase  
Cylindre, carter-vilebrequin  
Cilindro, cárter cigüeñal

**DOLMAR**



A member of the **Takita** Group

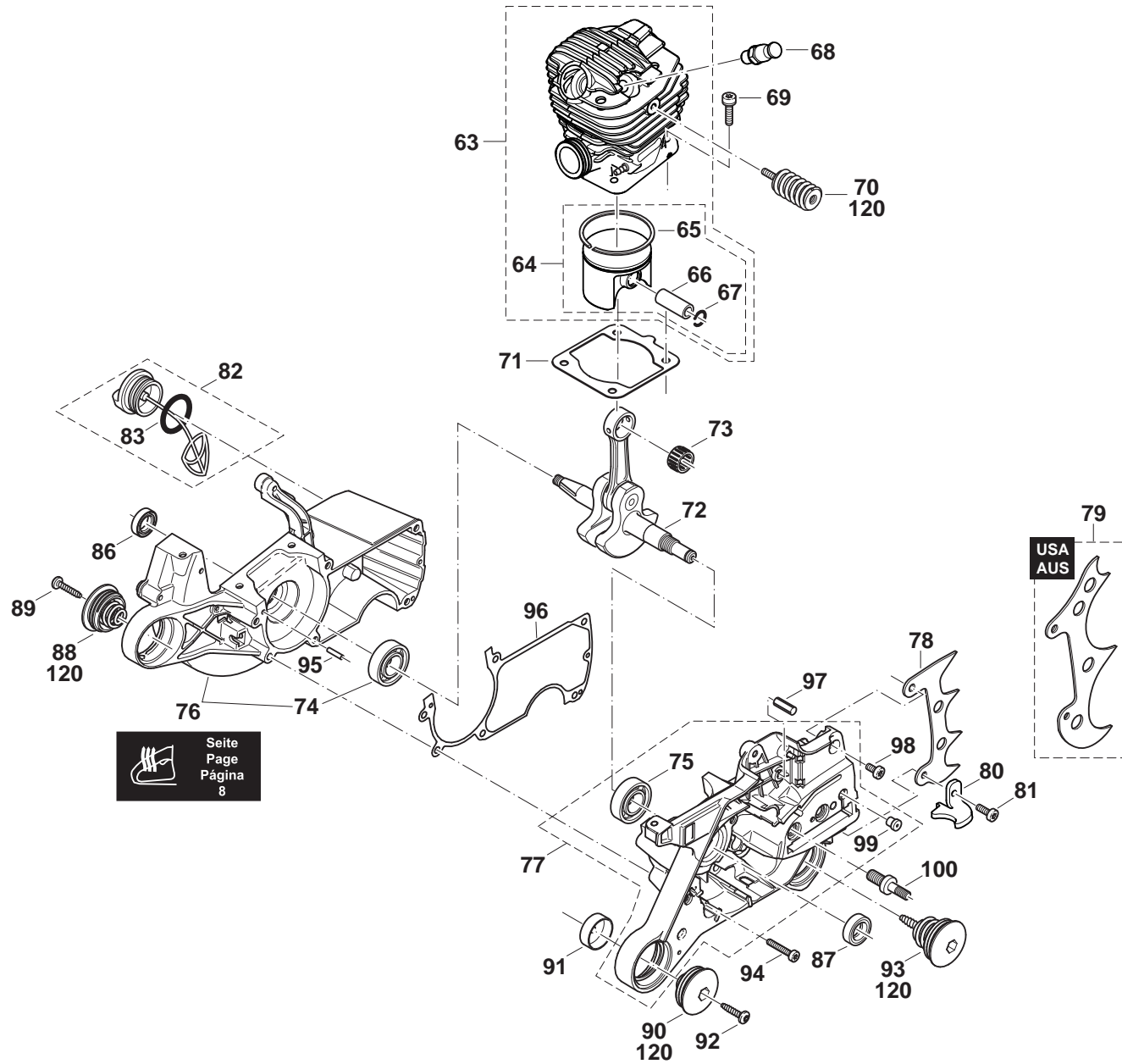

Seite  
Page  
Página  
8



PS-7310, PS-7310 H, PS-7910,  
PS-7910 H, PS-7310 , PS-7310  
H , PS-7910 , PS-7910 H

3

Zylinder, Kurbelgehäuse  
Cylinder, crankcase  
Cylindre, carter-vilebrequin  
Cilindro, cárter cigüeñal

**DOLMAR**  
A member of the **Takita** Group

Seite / Page	Pos.	PS-7310	PS-7310 H	PS-7910	PS-7910 H	PS-7910 (USA, CDN)	PS-7910 H (USA, CDN)	PS-7910 (USA, CDN)	PS-7910 H (USA, CDN)	Teil-Nr. Part No. No. de pièce No. de pieza	Hinweise Notes Renseign. Nota	Bezeichnung	Spezifikation Specification	Description	Désignation	Denominación
3	63	1	1			1	1			039 130 033		ZYLINDER / KOLBEN KPL.	D=50 DECO	CYLINDER / PISTON CPL.	CYLINDRE ET PISTON CPL.	CILINDRO CON PISTÓN CPL.
3	63			1	1			1	1	038 130 071		ZYLINDER / KOLBEN KPL.	D=52 DECO	CYLINDER / PISTON CPL.	CYLINDRE ET PISTON CPL.	CILINDRO CON PISTÓN CPL.
3	64	1	1			1	1			395 132 050		KOLBEN KPL.	ø 50	PISTON CPL.	PISTON CPL.	PISTÓN CPL.
3	64			1	1			1	1	038 132 070		KOLBEN KPL.	ø 52	PISTON CPL.	PISTON CPL.	PISTÓN CPL.
3	65	1	1			1	1			394 132 020		KOLBENRING	ø 50	PISTON RING	SEGMENT DE PISTON	SEGMENTO DE PISTÓN
3	65			1	1			1	1	038 132 020		KOLBENRING	ø 52	PISTON RING	SEGMENT DE PISTON	SEGMENTO DE PISTÓN
3	66	1	1			1	1			119 132 030		KOLBENBOLZEN		PISTON PIN	AXE DE PISTON	PERNO DE PISTÓN
3	66			1	1			1	1	038 132 041		KOLBENBOLZEN		PISTON PIN	AXE DE PISTON	PERNO DE PISTÓN
3	67	2	2	2	2	2	2	2	2	038 132 080		SPRENGRING		CLIP	ANNEAU RESSORT	ANILLO ELÁSTICO
3	68	1	1	1	1	1	1	1	1	038 118 180		DEKOMPRESSIONSVENTIL		DECOMPRESSION VALVE	SOUPAPE DE DÉCOMPRESSION	VÁLVULA DE DECOMPRESIÓN
3	69	4	4	4	4	4	4	4	4	908 805 235		INNENSTERNSCHRAUBE MIT SPANNSCHEIBE	M5x23	SCREW	VIS	TORNILLO
3	70	1	1	1	1	1	1	1	1	038 114 152		FEDER MIT 2 GEWINDEEINSÄTZEN		SPRING W. THREADED INSERT	RESSORT AVEC FILETAGE	MUELLE CON ROSCA
3	71	1	1	1	1	1	1	1	1	965 531 160		ZYLINDERFUßDICHTUNG, METALL		GASKET, METAL	JOINT, MÉTAL	JUNTA, METAL
3	72	1	1	1	1	1	1	1	1	038 120 200		KURBELWELLE KPL.		CRANKSHAFT CPL.	VILEBREQUIN CPL.	CIGÜEÑAL CPL.
3	73	1	1	1	1	1	1	1	1	962 210 121		NADELKLANZ		NEEDLE CAGE	CAGE À AIGUILLES	JAULA DE AGUJAS
3	74	1	1	1	1	1	1	1	1	960 102 152		KUGELLAGER (EINKLEBEN)	6202	BALL BEARING (USE GLUE)	ROULEMENT À BILLES (À COLLER)	RODAM. DE BOLAS (A COLAR)
3	75	1	1	1	1	1	1	1	1	960 102 179		KUGELLAGER	6203 C4	BALL BEARING	ROULEMENT À BILLES	RODAMIENTO DE BOLAS
3	76	1		1		1		1		038 111 160		KURBELGEHÄUSE MS ROT		CRANKC. MAG. SIDE RED	CARTER-COTÉ MAGN. ROUGE	CÁRTER CIG. LADO MAG. ROJO
3	77	1	1	1	1	1	1	1	1	038 111 141		KURBELGEHÄUSE KS ROT		CRANKC. CLUTCH SIDE RED	CARTER-COTÉ EMBR. ROUGE	CÁRTER CIG. LADO EMBR. ROJO
3	78	1	1	1	1					038 250 021		ZACKENLEISTE		SPIKE BAR	BARRE DENTÉE	BARRA DENTADA
3	79	1	1	1	1	1	1	1	1	038 250 202		ZACKENLEISTE	USA, AUS	SPIKE BAR	BARRE DENTÉE	BARRA DENTADA
3	80	1	1	1	1	1	1	1	1	038 111 171		KETTENFÄNGER		CHAIN CATCH	ARRÊTE-CHAÎNE	BULÓN DE RETENCIÓN
3	81	1	1	1	1	1	1	1	1	908 805 205		ZYLINDERSCHRAUBE MIT SPANNSCHEIBE	M5X20	SCREW	VIS	TORNILLO
3	82	1	1	1	1	1	1	1	1	010 114 050		TANKVERSCHLUß KPL. (KRAFTST.)		TANK CAP ASSY. (FUEL)	BOUCHON RÉSERV. CPL. (CARB.)	CIERRE DE DEPÓSITO CPL.
3	83	1	1	1	1	1	1	1	1	963 228 030		O-RING	ø 28x3	PACKING RING	BAGUE-JOINT	ANILLO DE GUARNICIÓN
3	86	1	1	1	1	1	1	1	1	962 900 052		RADIALDICHRING	ø15/24x7	RADIAL RING	JOINT RADIAL	JUNTA RADIAL
3	87	1	1	1	1	1	1	1	1	962 900 061		RADIALDICHRING	17X28X5/4	RADIAL RING	JOINT RADIAL	ANILLO RADIAL
3	88	1	1	1	1	1	1	1	1	038 114 130		FEDER KPL. MIT KAPPE		SPRING CPL. WITH CAP	RESSORT CPL.	RESORTE CPL.
3	89	1	1	1	1	1	1	1	1	913 455 204		SCHRAUBE INNEN6RD ZK K	5,5x20	SCREW	VIS	TORNILLO
3	90	1	1	1	1	1	1	1	1	038 114 130		FEDER KPL. MIT KAPPE		SPRING CPL. WITH CAP	RESSORT CPL.	RESORTE CPL.
3	91	1	1	1	1	1	1	1	1	038 114 191		TOPF		POT	CAPUCHON	POTE
3	92	1	1	1	1	1	1	1	1	913 455 204		SCHRAUBE INNEN6RD ZK K	5,5x20	SCREW	VIS	TORNILLO
3	93	1	1	1	1	1	1	1	1	038 114 141		FEDER KPL. MIT KAPPE		SPRING CPL. WITH CAP	RESSORT CPL.	RESORTE CPL.
3	94	6	6	6	6	6	6	6	6	908 005 305		INNENSTERN-SCHRAUBE	M5x30	SCREW	VIS	TORNILLO
3	95	2	2	2	2	2	2	2	2	936 430 160		SPIRALSPANNSTIFT	3X16	CLAMPING PIN	GOUPILLE	PASADOR
3	96	1	1	1	1	1	1	1	1	038 111 042		KURBELGEHÄUSEDICHTUNG		GASKET	JOINT	JUNTA
3	97	1	1	1	1	1	1	1	1	934 660 250		KERBSTIFT	6x24	SLOTTED PIN	GOUPILLE FENDUE	CLAVIJA MUESCA

PS-7310, PS-7310 H, PS-7910,  
PS-7910 H, PS-7310 , PS-7310  
H , PS-7910 , PS-7910 H

3

Zylinder, Kurbelgehäuse  
Cylinder, crankcase  
Cylindre, carter-vilebrequin  
Cilindro, cárter cigüeñal

**DOLMAR**  
A member of the *Takita* Group

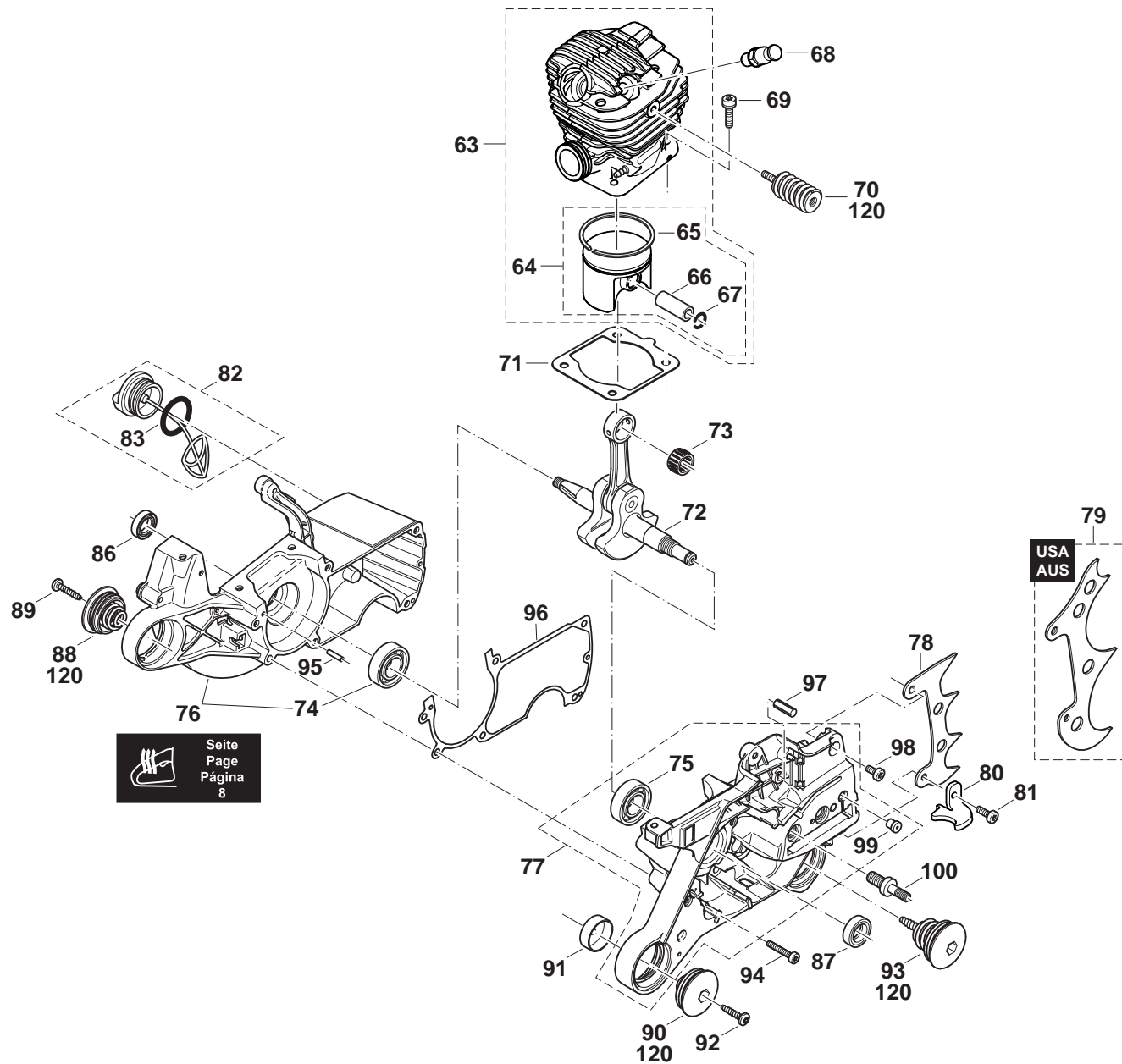

Seite  
Page  
Página  
8

PS-7310, PS-7310 H, PS-7910,  
PS-7910 H, PS-7310 , PS-7310  
H , PS-7910 , PS-7910 H

3

Zylinder, Kurbelgehäuse  
Cylinder, crankcase  
Cylindre, carter-vilebrequin  
Cilíndro, cárter cigüeñal

**DOLMAR**



A member of the **Takita** Group

Seite / Page	Pos.	PS-7310	PS-7310 H	PS-7910	PS-7910 H	PS-7310 (USA,CDN)	PS-7310 H (USA,CDN)	PS-7910 (USA,CDN)	PS-7910 H (USA,CDN)	Teil-Nr. Part No. No. de pièce No. de pieza	Hinweise Notes Renseign. Nota	Bezeichnung	Spezifikation Specification	Description	Désignation	Denominación
3	98	1	1	1	1	1	1	1	1	908 005 125		INNENSTERN-SCHRAUBE	M5x12	SCREW	VIS	TORNILLO
3	99	1	1	1	1	1	1	1	1	010 245 030		BELÜFTUNGSVENTIL		VENT VALVE	SOUPAPE D AERATION	VALVULA VENTILACION
3	100	2	2	2	2	2	2	2	2	038 232 011		BEFESTIGUNGSBOLZEN		TIGHTEN LOCKING BOLT	BOULON DE FIXATION	PERNO DE FIJACIÓN
3	120	1	1	1	1	1	1	1	1	010 114 039		FEDERN SATZ		SET OF SPRINGS	JEU DE RESSORTS	JUEGO DE RESORTES

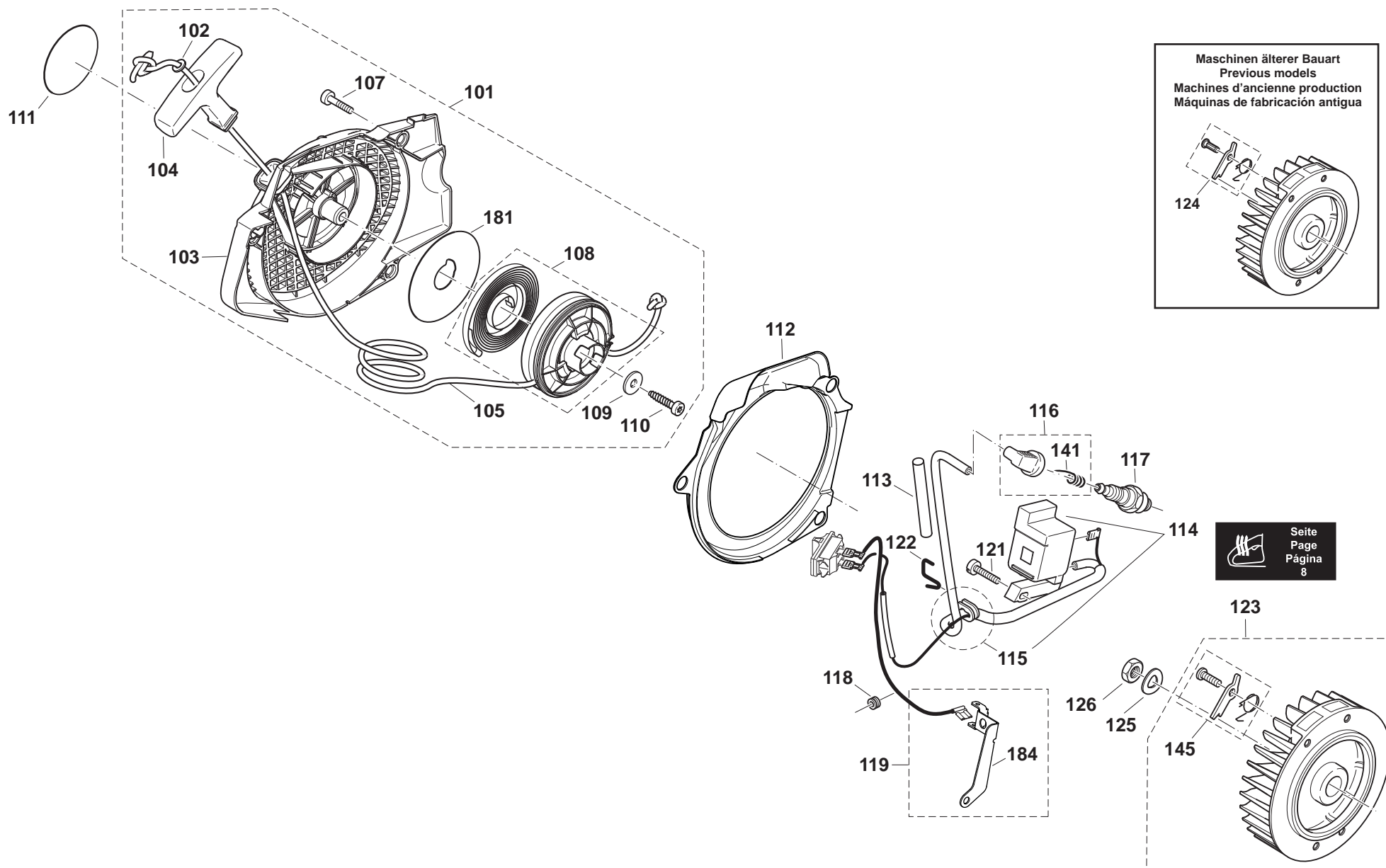

PS-7310, PS-7310 H, PS-7910,  
PS-7910 H, PS-7310 , PS-7310  
H , PS-7910 , PS-7910 H

4

Zündelektronik, Anwerfvorrichtung  
Ignition electronics, starter  
Allumage électronique, dispositif de démarrage  
Bobina encendido, dispositivo de arranque

**DOLMAR**  
A member of the **Takita** Group

Seite / Page	Pos.	PS-7310	PS-7310 H	PS-7910	PS-7910 H	PS-7910 (USA,CDN)	PS-7910 H (USA,CDN)	PS-7910 (USA,CDN)	PS-7910 H (USA,CDN)	Teil-Nr. Part No. No. de pièce No. de pieza	Hinweise Notes Renseign. Nota	Bezeichnung	Spezifikation Specification	Description	Désignation	Denominación
4	101	1	1	1	1	1	1	1	1	038 160 015		ANWERFVORRICHTUNG ROT KPL.	DD	STARTER ASSY. RED	DISPOS. DE DÉMARRAGE CPL.	DISPOS. DE ARRANQUE CPL. ROJO
4	102	1	1	1	1	1	1	1	1	928 405 000		SPANNSCHEIBE		DISC	DISQUE	ARANDELA
4	103	1	1	1	1	1	1	1	1	038 112 033		VENTILATORGEHÄUSE ROT	DD	FAN HOUSING RED	CARTER DE VENTILATEUR ROUGE	CÁRTER DE VENTILADOR ROJO
4	104	1	1	1	1	1	1	1	1	001 161 020		ANWERFGRIF		STARTER GRIP	POIGNÉE DE LANCEMENT	TIRADOR DE ARRANQUE
4	105	1	1	1	1	1	1	1	1	108 164 020		ANWERFSEIL	ø 3,5 x 980 mm	STARTER ROPE	CÂBLE DE DÉMARRAGE	CORDÓN DE ARRANQUE
4	105	1	1	1	1	1	1	1	1	985 000 155	ACC.	ANWERFSEIL	ø 3,5 x 100 m	STARTER ROPE	CORDE DE LANCEUR	CUERDA DE ARRANQUE
4	107	3	3	3	3	3	3	3	3	908 605 205		SCHRAUBE INNEN6RD	M5x20	H.L. SOCKET HEAD BOLT	VIS	TORNILLO
4	108	1	1	1	1	1	1	1	1	038 162 024		SEILTROMMEL KPL. MIT RÜCKHOLFEDER		CABLE DRUM CPL.	TAMBOUR DE CÂBLE CPL.	TAMBOUR PARA CORDÓN CPL.
4	109	1	1	1	1	1	1	1	1	924 605 510		SCHEIBE	Ø 5,5x18x1,6	WASHER	RONDELLE	ARANDELA
4	110	1	1	1	1	1	1	1	1	913 455 204		SCHRAUBE INNEN6RD ZK K	5,5x20	SCREW	VIS	TORNILLO
4	111	1	1			1	1			980 115 706		SCHILD	PS-7310	LABEL	PLAQUE	CALCOMANIA
4	111			1	1			1	1	980 115 705		SCHILD	PS-7910	LABEL	PLAQUE	CALCOMANIA
4	112	1	1	1	1	1	1	1	1	038 112 060		LUFTFÜHRUNG		AIR DUCT	PLAQUE DE VENTILATION	PLACA VENTILACIÓN
4	113	m	m	m	m	m	m	m	m	970 502 110		ISOLIERSCHLAUCH	A6X0,5 140 mm	INSULATING HOSE	TUYAU ISOLANT	MANGO AISLANTE
4	114	1	1	1	1	1	1	1	1	038 143 200		ZÜNDSPULE KPL.		IGNITION COIL	BOBINE D' ALLUMAGE	BOBINA ENCENDIDO
4	115	1	1	1	1	1	1	1	1	038 143 030		KABELBAUM		CABLE HARNESS	FAISCEAU DE CÂBLES	MAZO DE CABLES
4	116	1	1	1	1	1	1	1	1	957 604 240		ZÜNDKERZENSTECKER KPL.		SPARK PLUG CAP CPL.	FICHE DE BOUGIE, CPL.	TAPA DE BUJIA CPL.
4	117	1	1	1	1	1	1	1	1	965 603 021		ZÜNDKERZE		SPARK PLUG	BOUGIE	BUJÍA
4	118	1	1	1	1	1	1	1	1	965 401 011		GUMMITÜLLE		RUBBER BUSHING	GAINE CAOUTCHOUC	BOQUILLA DE CAUCHO
4	119	1	1	1	1	1	1	1	1	957 311 590		MASSELEITUNG	SET	EARTH CABLE	FIL DE MASSE	CONDUCCIÓN A MASA
4	121	2	2	2	2	2	2	2	2	908 304 205		SCHRAUBE	M4x20	SCREW	VIS	TORNILLO
4	122	1	1	1	1	1	1	1	1	038 111 110		KLAMMER		CLIP	AGRAFE	GRAPA
4	123	1		1		1		1		957 141 003		ERSATZTEILSET POLRAD KPL	D120	FLYWHEEL	ROUE POLAIRE	VOLANTE ENCENDIDO
4	124	2	2	2	2	2	2	2	2	108 166 051	=> 2010-09	ANWERFKLINKE KPL. (MIT BOLZEN)		STARTER RATCHET CPL. (WITH BOLT)	CLIQUET CPL. (AVEC BOULON)	TRINQUETE ARRANQUE CPL. (CON BULÓN)
4	125	1	1	1	1	1	1	1	1	926 208 001		FEDERSCHEIBE	B8	SPRING WASHER	RONDELLE ÉLASTIQUE	DISCO AMORTIGUADOR
4	126	1	1	1	1	1	1	1	1	920 208 024		6KT-MUTTER	M8x1	HEXAGONAL NUT	ECROU HEXAGONAL	TUERCA HEXAGONAL
4	141	1	1	1	1	1	1	1	1	965 604 180		FEDER		SPRING	RESSORT	MUELLE
4	145	2	2	2	2	2	2	2	2	038 166 050	2010-10 =>	ANWERFKLINKE KPL. (MIT SCHRAUBE)		STARTER RATCHET CPL. (WITH SCREW)	CLIQUET CPL. (AVEC VIS)	TRINQUETE ARRANQUE CPL. (CON TORNILLO)
4	181	1	1	1	1	1	1	1	1	038 162 050		AUSGLEICHSCHEIBE		SPACER	RONDELLE	ARANDELA
4	184	1	1	1	1	1	1	1	1	038 111 150		KLAMMER MIT MASSEARM		CLAMP	CRAMPON	GRAPA

PS-7310, PS-7310 H, PS-7910,  
PS-7910 H, PS-7310 , PS-7310  
H , PS-7910 , PS-7910 H

5

Öpumpe, Kupplung  
Oil pump, clutch  
Pompe à huile, embrayage  
Bomba de aceite, embrague

**DOLMAR**



A member of the **Trakita** Group

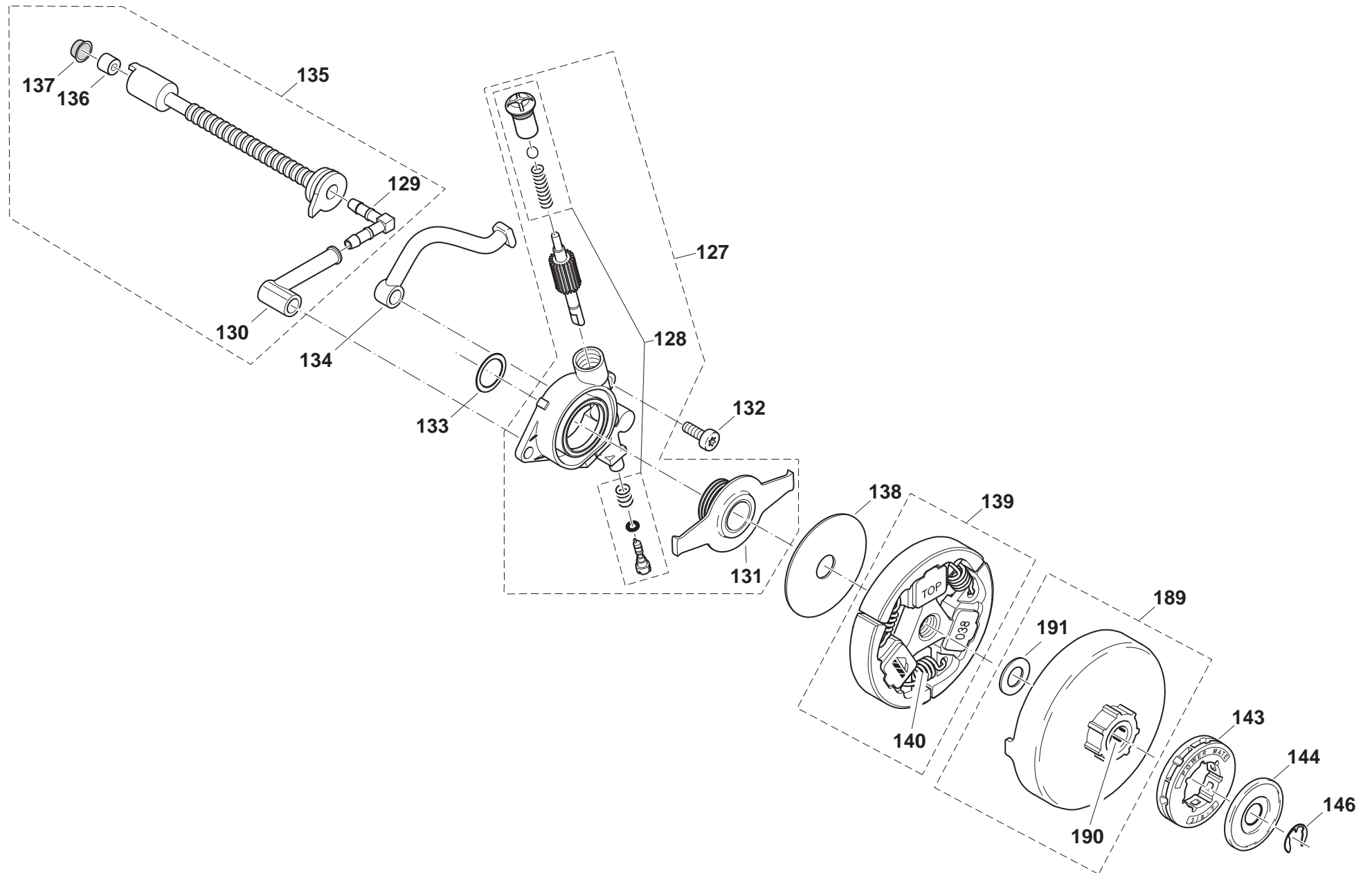

PS-7310, PS-7310 H, PS-7910,  
PS-7910 H, PS-7310 , PS-7310  
H , PS-7910 , PS-7910 H

5

Ölpumpe, Kupplung  
Oil pump, clutch  
Pompe à huile, embrayage  
Bomba de aceite, embrague

**DOLMAR**  
A member of the **Takita** Group

Seite / Page	Pos.	PS-7310	PS-7310 H	PS-7910	PS-7910 H	PS-7910 (USA,CDN)	PS-7910 H (USA,CDN)	PS-7910 (USA,CDN)	PS-7910 H (USA,CDN)	Teil-Nr. Part No. No. de pièce No. de pieza	Hinweise Notes Renseign. Nota	Bezeichnung	Spezifikation Specification	Description	Désignation	Denominación
5	127	1	1	1	1	1	1	1	1	038 245 011		ÖLPUMPE KPL.		OIL PUMP CPL.	POMPE À HUILE CPL.	BOMBA DE ACEITE CPL.
5	128	1	1	1	1	1	1	1	1	030 245 070		REPARATURSATZ KPL.		REPAIR KIT CPL.	JEU DE RÉPARATION CPL.	JUEGO DE REPARAR CPL.
5	129	1	1	1	1	1	1	1	1	001 245 140		WINKELNIPPEL		ANGULAR NIPPLE	TÉTON COUDÉ	BOUQUILLA DE TUBO
5	130	1	1	1	1	1	1	1	1	038 245 110		ÖLLEITUNG		OIL LINE	CONDUITE HUILE	TUBO ACEITE
5	131	1	1	1	1	1	1	1	1	038 245 031		PUMPENANTRIEB		PUMP DRIVE	LE COMMANDE DE POMPE	PROPULSOR DE LA BOMBA
5	132	2	2	2	2	2	2	2	2	908 005 125		INNENSTERN-SCHRAUBE	M5x12	SCREW	VIS	TORNILLO
5	133	1	1	1	1	1	1	1	1	038 224 021		ANLAUFSCHIEBE		DISC	DISQUE	ARANDELA
5	134	1	1	1	1	1	1	1	1	038 245 061		ÖLDRUCKLEITUNG		OIL LINE	CONDUITE HUILE	TUBO ACEITE
5	135	1	1	1	1	1	1	1	1	038 245 020		ÖLSAUGLEITUNG KPL.		SUCTION LINE OIL CPL.	CONDUITE D'ASPIR. HUILE CPL.	CONDUCTO DE ASPIR. ACEITE CPL.
5	136	1	1	1	1	1	1	1	1	900 005 066		DISTANZRING		DISTANCE RING	BAGUE DE DISTANCE	ANILLO SEPARADOR
5	137	1	1	1	1	1	1	1	1	963 601 100		SIEB		SCREEN	FILTRE	TAMIZ
5	138	1	1	1	1	1	1	1	1	001 182 042		FÜHRUNGSSCHIEBE	44,5x1x12	DISC	DISQUE	DISCO
5	139	1	1	1	1	1	1	1	1	038 180 012		KUPPLUNG KPL.		CLUTCH ASSY.	EMBRAYAGE CPL.	EMBRAGUE CPL.
5	140	3	3	3	3	3	3	3	3	024 184 021		ZUGFEDER		SPRING	RESSORT	RESORTE
5	143	1	1	1	1	1	1	1	1	119 224 070		ZAHNKRANZ	3/8" Z=7	RIM SPROCKET	PIGNON	PIÑÓN
5	144	1	1	1	1	1	1	1	1	181 224 081		TOPFSCHIEBE		DISC	DISQUE	ARANDELA
5	146	1	1	1	1	1	1	1	1	927 408 000		SICHERUNGSSCHIEBE	D=8X1,3	WASHER	RONDELLE	ARANDELA
5	189	1	1	1	1	1	1	1	1	957 223 092		KUPPLUNGSTROMMEL		CLUTCH DRUM	TAMBOUR	TAMBOR
5	190	1	1	1	1	1	1	1	1	962 300 009		NADELHÜLSE	10/14X12	NEEDLE SLEEVE	DOUILLE D'AIGUILLE	CASQUILLO DE AGUJA
5	191	1	1	1	1	1	1	1	1	038 223 100		DISTANZSCHIEBE	10,2/18x1,7	SPACER WASHER	RONDELLE D'ÉCARTEMENT	DISCO DISTANCIADOR



PS-7310, PS-7310 H, PS-7910,  
PS-7910 H, PS-7310 , PS-7310  
H , PS-7910 , PS-7910 H

6

Kettenbremse  
Chain brake  
Frein de chaîne  
Freno de cadena

**DOLMAR**



A member of the **Takita** Group

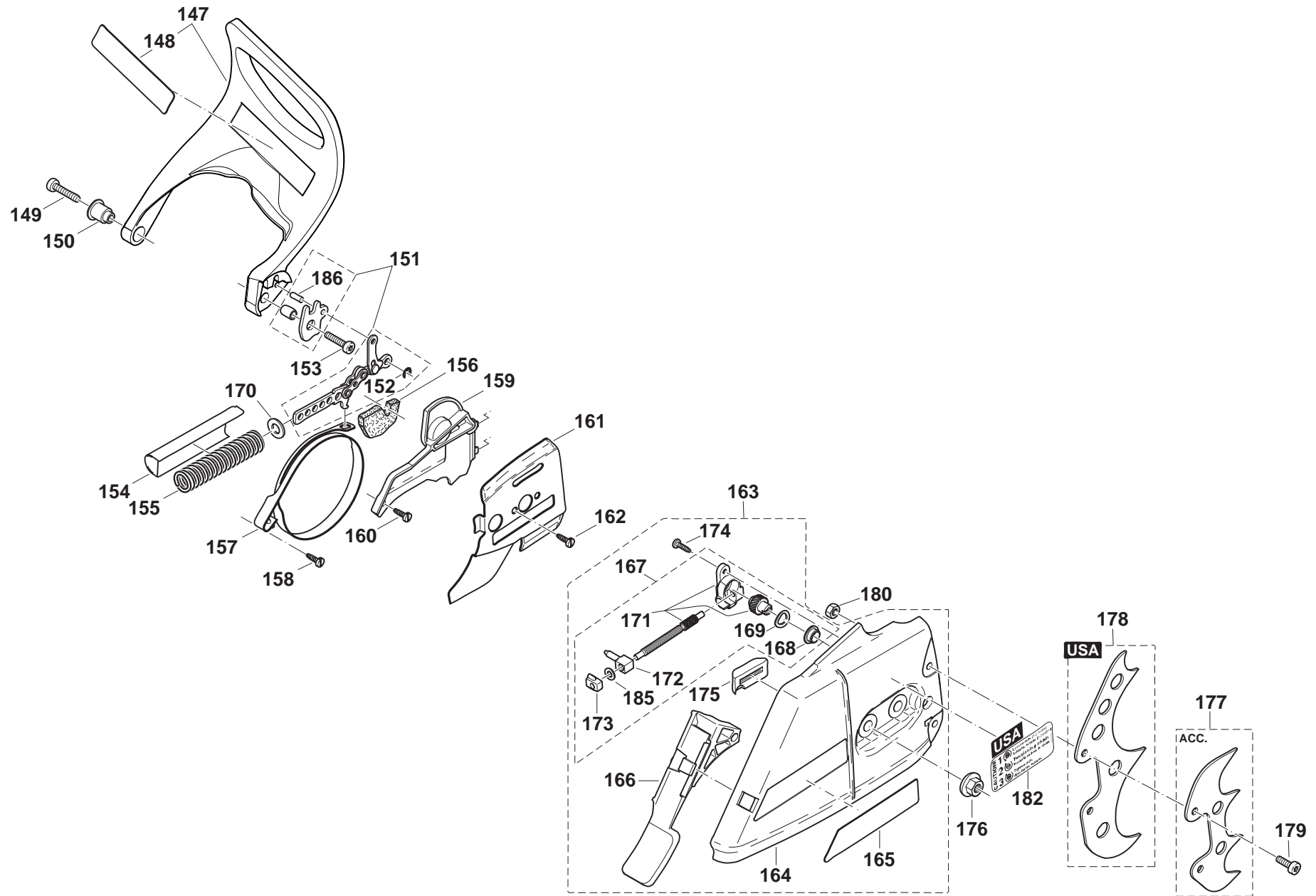

PS-7310, PS-7310 H, PS-7910,  
PS-7910 H, PS-7310 , PS-7310  
H , PS-7910 , PS-7910 H

6

Kettenbremse  
Chain brake  
Frein de chaîne  
Freno de cadena

**DOLMAR**  
A member of the **Takita** Group

Seite / Page	Pos.	PS-7310	PS-7310 H	PS-7910	PS-7910 H	PS-7910 (USA,CDN)	PS-7910 H (USA,CDN)	PS-7910 (USA,CDN)	PS-7910 H (USA,CDN)	Teil-Nr. Part No. No. de pièce No. de pieza	Hinweise Notes Renseign. Nota	Bezeichnung	Spezifikation Specification	Description	Désignation	Denominación
6	147	1	1	1	1	1	1	1	1	038 213 221		HANDSCHUTZ KPL.	KAT	HAND GUARD CPL.	PROTÈGE-MAIN CPL.	PROTECTOR DE MANO CPL.
6	148	1	1	1	1	1	1	1	1	185 114 237		SCHILD HANDSCHUTZ		LABEL	PLAQUE	CALCOMANIA
6	148					1	1	1	1	980 115 897	USA	SICHERHEITS-AUFKLEBER	US WARNING SPARKS	CAUTION LABEL	PLAQUE	CALCOMANIA
6	149	1	1	1	1	1	1	1	1	908 405 205		SCHRAUBE INNEN6RD ZK	M5x20	H.L. SOCKET HEAD BOLT	VIS	TORNILLO
6	150	1	1	1	1	1	1	1	1	038 213 160		BUCHSE		BUSHING	DOUILLE	CASQUILLO
6	151	1	1	1	1	1	1	1	1	957 213 030		AUSRÜCKMECHANISMUS KPL.		BRAKING MECHANISM	MÉCANISME DE FREINAGE	MECANISMO DE FRENO
6	152	1	1	1	1	1	1	1	1	927 304 000		SICHERUNGSSCHEIBE		SAFETY WASHER	RONDELLE SÉCURITÉ	ARANDELA SEGURIDAD
6	153	1	1	1	1	1	1	1	1	908 805 205		ZYLINDERSCHRAUBE MIT SPANNSCHEIBE	M5X20	SCREW	VIS	TORNILLO
6	154	1	1	1	1	1	1	1	1	038 213 152		FEDERTOPF		POT	CAPUCHON	POTE
6	155	1	1	1	1	1	1	1	1	038 213 130		DRUCKFEDER		SPRING	RESSORT	RESORTE
6	156	1	1	1	1	1	1	1	1	038 213 200		SCHAUMSTOFFPLATTE		FOAM SPONGE	PLAQUE DE MOUSSE DE NYLON	CHAPA DE ESPUMA DE PLÁST.
6	157	1	1	1	1	1	1	1	1	038 213 010		BREMSBAND		BRAKE SPRING	RESSORT DE FREIN	CINTA DE FRENO
6	158	1	1	1	1	1	1	1	1	915 135 100		SCHNEIDSCHRAUBE	3,5x9,5	SCREW	VIS	TORNILLO
6	159	1	1	1	1	1	1	1	1	038 213 040		ABDECKPLATTE		PLATE	PLAQUE	PLANCHA
6	160	1	1	1	1	1	1	1	1	915 135 100		SCHNEIDSCHRAUBE	3,5x9,5	SCREW	VIS	TORNILLO
6	161	1	1	1	1	1	1	1	1	038 111 030		KETTENFÜHRUNGSBLECH		GUIDE PLATE	TÔLE DE GUIDAGE	CHAPA DE GUÍA
6	162	1	1	1	1	1	1	1	1	915 135 100		SCHNEIDSCHRAUBE	3,5x9,5	SCREW	VIS	TORNILLO
6	163	1	1	1	1	1	1	1	1	038 213 103		KETTENRADSCHUTZ KPL. ROT	DOLMAR	SPROCKET GUARD CPL. RED	PROTÈGE-PIGNON CPL. ROUGE	PROTECTOR DE PIÑÓN CPL. ROJO
6	164	1	1	1	1	1	1	1	1	038 213 035		KETTENRADSCHUTZ ROT		SPROCKET GUARD RED	PROTÈGE-PIGNON ROUGE	PROTECTOR DE PIÑÓN ROJO
6	165	1	1	1	1	1	1	1	1	980 114 593		SCHILD	DOLMAR	LABEL	PLAQUE	CALCOMANIA
6	166	1	1	1	1	1	1	1	1	038 213 190		SPANABWEISER		CHIP GUIDE	GUIDE DE COPEAUX	SALIDA DE VIRUTAS
6	167	1	1	1	1	1	1	1	1	957 213 023		KETTENSPANNANTRIEB KPL.		CHAIN TENSIONER CPL.	TENDEUR DE CHAÎNE CPL.	SENSOR DE LA CADENA CPL.
6	168	1	1	1	1	1	1	1	1	038 213 080		BUCHSE FÜR ANTRIEBSRAD		BUSHING	DOUILLE	CASQUILLO
6	169	1	1	1	1	1	1	1	1	038 213 230		FEDERSCHEIBE		SPRING WASHER	RONDELLE A RESSORT	ARANDELA ELASTICO
6	170	1	1	1	1	1	1	1	1	028 213 012		SCHEIBE		WASHER	RONDELLE	ARANDELA
6	171	1	1	1	1	1	1	1	1	957 213 040		SPANNSCHRAUBE SATZ		TENSIONING SCREW SET	VIS DE TENSION JEU	TORNILLO DE TENSIÓN JUEGO
6	172	1	1	1	1	1	1	1	1	038 213 091		SPANNMUTTER		TENSIONING NUT	ECROU DE TENSION	TUERCA DE TENSIÓN
6	173	1	1	1	1	1	1	1	1	038 213 070		SPANNSCHRAUBENLAGER		TENSIONING SCREW BEARING	PALIER DE LA VIS DE TENSION	SOPORTE DEL TORNILLO TENSOR
6	174	1	1	1	1	1	1	1	1	915 135 100		SCHNEIDSCHRAUBE	3,5x9,5	SCREW	VIS	TORNILLO
6	175	1	1	1	1	1	1	1	1	024 213 240		KETTENFÜHRUNG		CHAIN GUIDE	GUIDE CHAÎNE	GUÍA DE LA CADENA
6	176	2	2	2	2	2	2	2	2	923 208 004		6KT-MUTTER	M8	HAXAGONAL NUT	ECROU HEXAGONAL	TUERCA HEXAGONAL
6	177	1	1	1	1					957 250 060	ACC.	ZACKENLEISTE KETTENDECKEL KPL.		SPIKE BAR CPL.	BARRE DENTÉE CPL.	BARRA DENTADA CPL.
6	178	1	1	1	1	1	1	1	1	038 250 212	USA	ZACKENLEISTE KETTENDECKEL	USA	SPIKE BAR	BARRE DENTÉE	BARRA DENTADA
6	179	2	2	2	2	2	2	2	2	908 005 125		INNENSTERN-SCHRAUBE	M5x12	SCREW	VIS	TORNILLO
6	180	2	2	2	2	2	2	2	2	920 405 000		6KT-MUTTER	M5	HEXAGONAL NUT	ECROU HEXAGONAL	TUERCA HEXAGONAL
6	182					=	=	=	=	980 114 925	USA	SCHILD KETTENSANNER	USA	LABEL	PLAQUE	CALCOMANIA

PS-7310, PS-7310 H, PS-7910,  
PS-7910 H, PS-7310 , PS-7310  
H , PS-7910 , PS-7910 H

6

Kettenbremse  
Chain brake  
Frein de chaîne  
Freno de cadena

**DOLMAR**



A member of the **Takita** Group

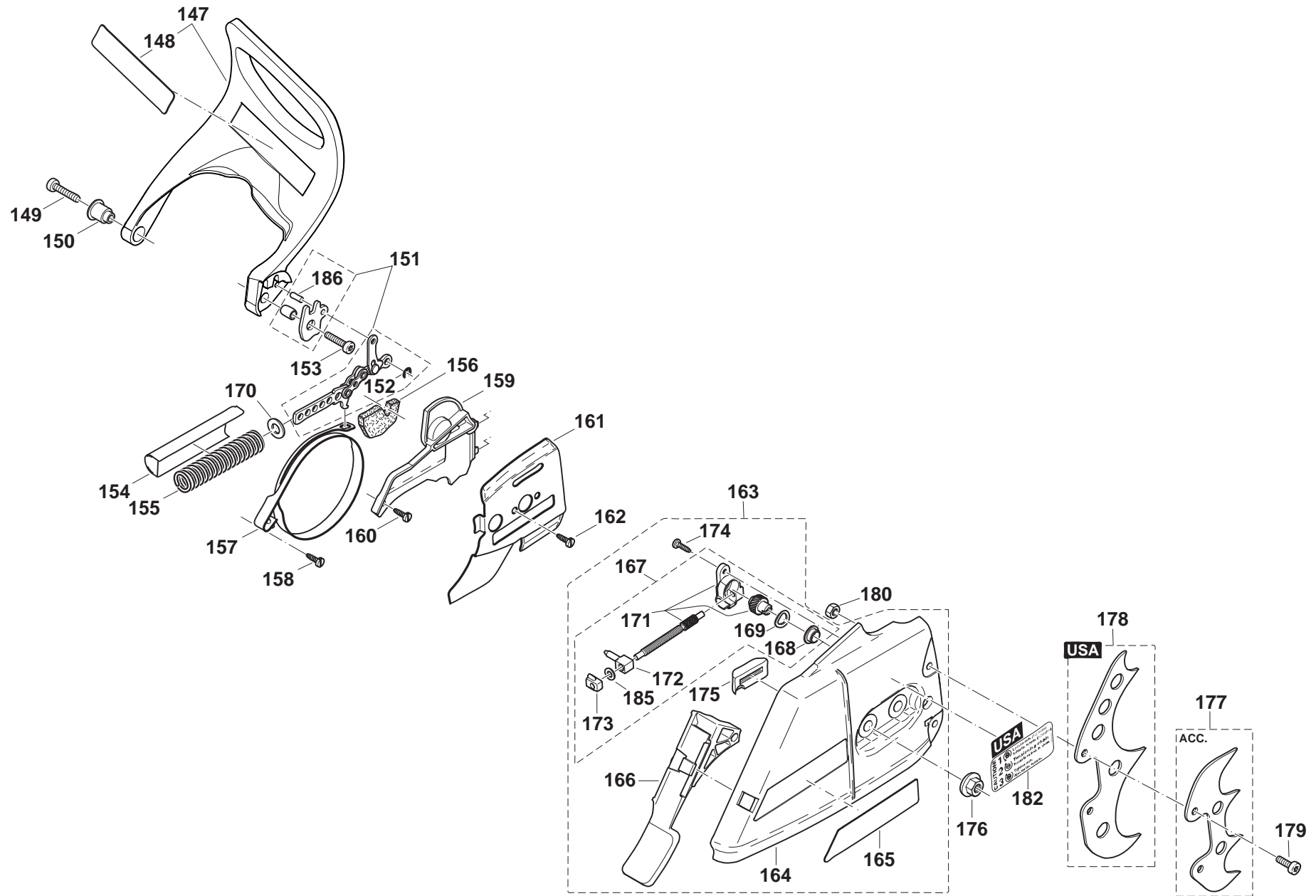

PS-7310, PS-7310 H, PS-7910,  
PS-7910 H, PS-7310 , PS-7310  
H , PS-7910 , PS-7910 H

6

Kettenbremse  
Chain brake  
Frein de chaîne  
Freno de cadena

**DOLMAR**  
  
A member of the **Makita** Group

Seite / Page	Pos.	PS-7310	PS-7310 H	PS-7910	PS-7910 H	PS-7310 (USA,CDN)	PS-7310 H (USA,CDN)	PS-7910 (USA,CDN)	PS-7910 H (USA,CDN)	Teil-Nr. Part No. No. de pièce No. de pieza	Hinweise Notes Renseign. Nota	Bezeichnung	Spezifikation Specification	Description	Désignation	Denominación
6	185	1	1	1	1	1	1	1	1	924 104 300		SCHEIBE	A 4,3	WASHER	RONDELLE	ARANDELA
6	186	1	1	1	1	1	1	1	1	935 940 100		ZYLINDERSTIFT	4X10	CYLINDRICAL PIN	GOUPILLE CYL.	PRISIONERO

PS-7310, PS-7310 H, PS-7910,  
PS-7910 H, PS-7310 , PS-7310  
H , PS-7910 , PS-7910 H

7

Vergaser  
Carburetor  
Carburateur  
Carburador

**DOLMAR**  
A member of the *Takita* Group

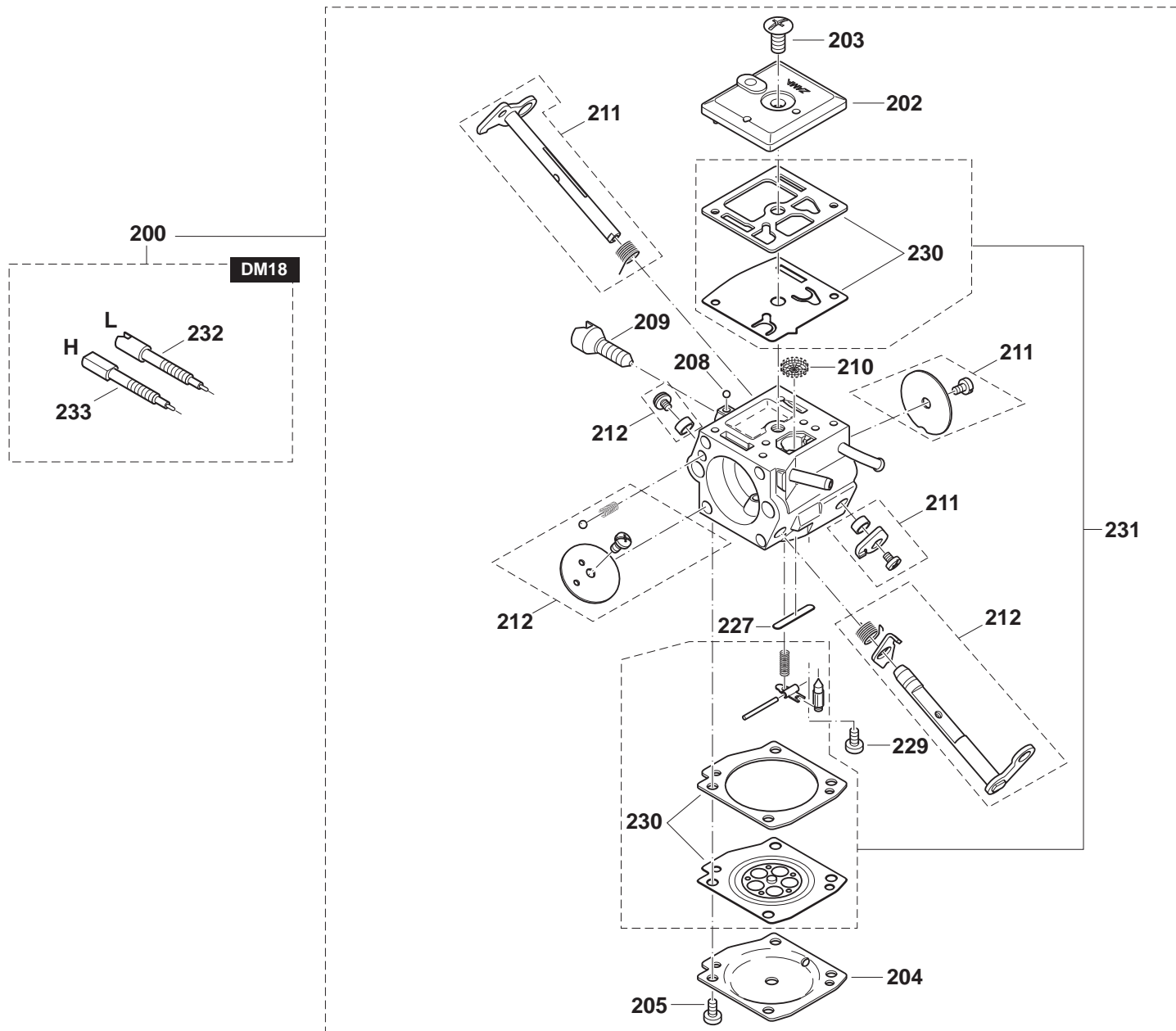

PS-7310, PS-7310 H, PS-7910,  
PS-7910 H, PS-7310 , PS-7310  
H , PS-7910 , PS-7910 H

7

Vergaser  
Carburetor  
Carburateur  
Carburador

**DOLMAR**  
A member of the **Takita** Group

Seite / Page	Pos.	PS-7310	PS-7310 H	PS-7910	PS-7910 H	PS-7910 (USA,CDN)	PS-7310 H (USA,CDN)	PS-7910 (USA,CDN)	PS-7910 H (USA,CDN)	Teil-Nr. Part No. No. de pièce No. de pieza	Hinweise Notes Renseign. Nota	Bezeichnung	Spezifikation Specification	Description	Désignation	Denominación
7	200	1	1	1	1	1	1	1	1	038 153 515		VERGASER MIT EINSTELLFÜHRUNG	DM18/A DD - (regulated market)	CARBURETOR WITH GUIDE	CARBURATEUR P. GUIDAGE D' AJUSTAGE	CARBURADOR P. GUÍA DE AJUSTE
7	202	1	1	1	1	1	1	1	1	038 153 030		PUMPENDECKEL		PUMP COVER	COUVERCLE DE POMPE	TAPA DE BOMBA
7	203	1	1	1	1	1	1	1	1	038 153 360		SCHRAUBE FÜR PUMPENDECKEL		SCREW	VIS	TORNILLO
7	204	1	1	1	1	1	1	1	1	038 153 540		REGELDECKEL KPL. SLR	H DD - (regulated market)	DIAPHRAGM COVER ASSY	COUVERCLE DE MEMBRANE CPL.	TAPA DE MEMBRANA CPL.
7	205	4	4	4	4	4	4	4	4	001 153 020		SCHRAUBE FÜR REGELDECKEL		SCREW	VIS	TORNILLO
7	208	1	1	1	1	1	1	1	1	038 153 210		ARRETIERKUGEL		FRICTION BALL	BILLE DE ARRÊT	BOLA
7	209	1	1	1	1	1	1	1	1	038 153 220		LEERLAUF-ANSCHLAGSCHR AUBE	S	IDLE STOP SCREW	VIS DE BUTÉE DE RALENTI	TORNILLO DE TOPE
7	210	1	1	1	1	1	1	1	1	036 153 040		SIEB		SCREEN	TAMIS	TAMIZ
7	211	1	1	1	1	1	1	1	1	038 153 570		REP.-SATZ DROSSELWELLE		KIT THROTTLE SHAFT	JEU AXE CLAPET D'ÉTRANG.	JUEGO EJE VÁLVULA REG.
7	212	1	1	1	1	1	1	1	1	038 153 580		REP.-SATZ CHOKEWELLE		KIT CHOKE SHAFT	JEU AXE CLAPET D'AIR	JUEGO EJE VÁLVULA AIRE
7	227	1	1	1	1	1	1	1	1	038 153 350		VERSCHLUßSCHEIBE		PLUG-WELCH	RONDELLE DE FERMETURE	DISCO DE CIERRE
7	229	1	1	1	1	1	1	1	1	028 153 200		SCHRAUBE		SCREW	VIS	TORNILLO
7	230	1	1	1	1	1	1	1	1	038 153 550		DICHTUNG UND MEMBRAN, SATZ (INKL. PUMPENMEMBRAN GUMMI+MYLAR)		SET DIAPHRAGM / GASKETS (INCL. PUMP DIAPHRAGM RUBBER+MYLAR)	JEU DE MEMBRANES / JOINTS (INCL. MEMBRANE DE POMPE CAOUTCH.+MYLAR)	JUEGO MEMBRANAS / JUNTAS (INCL. MEMBRANA DE LA BOMBA CAUCHO+MYLAR)
7	231	1	1	1	1	1	1	1	1	038 153 560		REPARATURSATZ VERGASER		REBUILD KIT	JEU DE RÉPARATION	JUEGO DE REPARAR
7	232	1	1	1	1	1	1	1	1	038 153 232		STELLSCHRAUBE	L	IDLE ADJUSTMENT SCREW	VIS DE RÉGL. DE RALENTI	TORNILLO REGULADOR
7	233	1	1	1	1	1	1	1	1	038 153 301		STELLSCHRAUBE	H DD - (regulated market)	MAIN ADJUSTMENT SCREW	VIS DE RÉGL. PLEIN GAZ	TORNILLO REGULADOR

PS-7310, PS-7310 H, PS-7910,  
PS-7910 H, PS-7310 , PS-7310  
H , PS-7910 , PS-7910 H

8

Spezialteile für Ausrüstung mit elektrischer Griffheizung  
Special parts for version with electric handle heating  
Pièces spéciales pour version avec chauffage de la poignée (électrique)  
Piezas especiales por tipo con calefacción eléctrica de mango

**DOLMAR**  
A member of the *Takita* Group

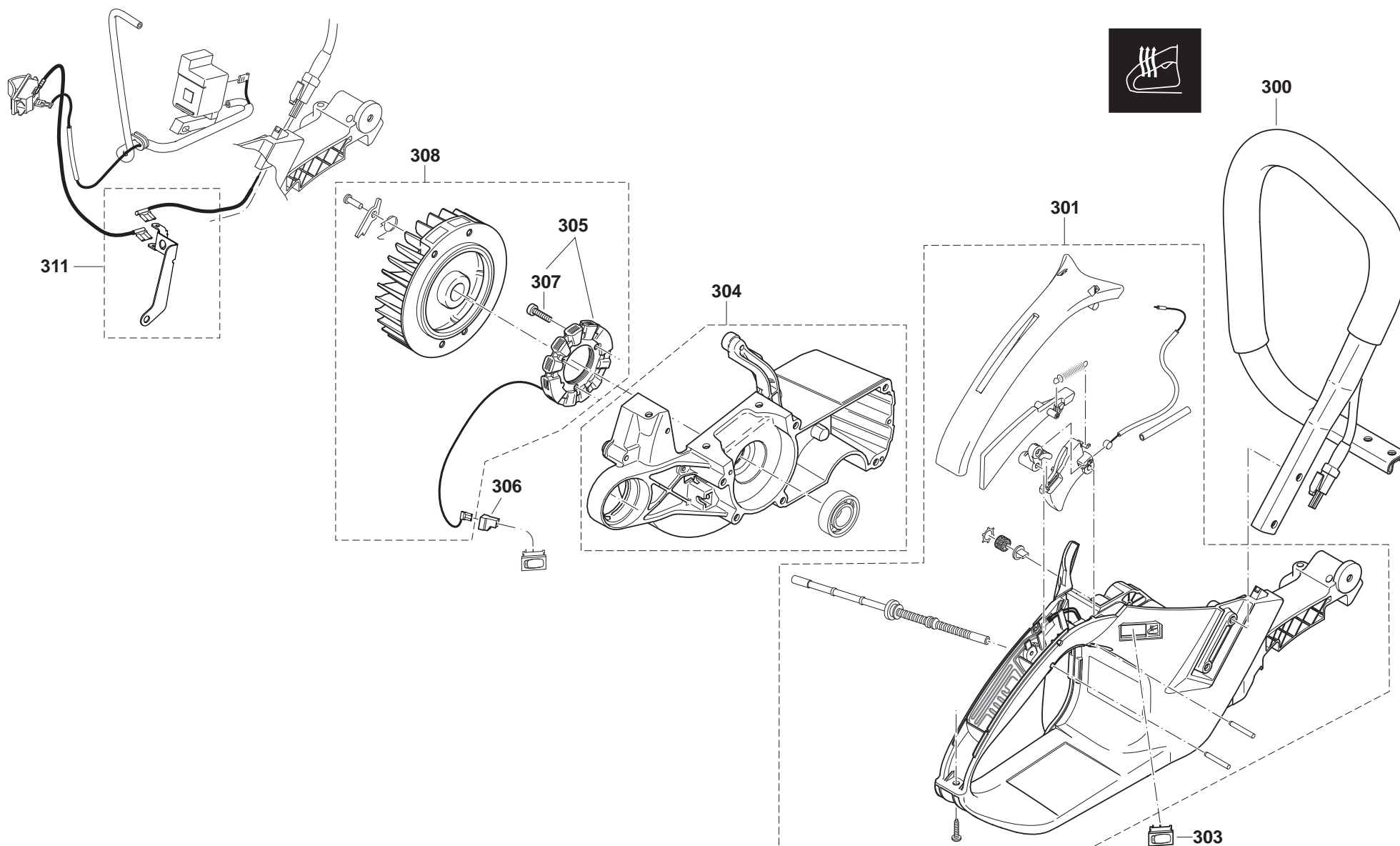



PS-7310, PS-7310 H, PS-7910,  
PS-7910 H, PS-7310 , PS-7310  
H , PS-7910 , PS-7910 H

8

Spezialteile für Ausrüstung mit elektrischer Griffheizung  
Special parts for version with electric handle heating  
Pièces spéciales pour version avec chauffage de la poignée (électrique)  
Piezas especiales por tipo con calefacción eléctrica de mango

**DOLMAR**  
A member of the **Takita** Group

Seite / Page	Pos.	PS-7310 H	PS-7910 H	PS-7310 H (USA, CAN)	PS-7910 H (USA, CAN)	Teil-Nr. Part No. No. de pièce No. de pieza	Hinweise Notes Renseign. Nota	Bezeichnung	Spezifikation Specification	Description	Désignation	Denominación
8	300	1	1	1	1	038 310 031		BÜGELGRIFF KPL. (HEIZUNG)	HEATING	TUBULAR HANDLE ASSY.	POIGNÉE TUBULAIRE CPL.	MANGO TUBULAR CPL.
8	301	1	1	1	1	038 114 079		TANK KPL. ROT (HEIZUNG)		TANK CPL. RED HEATING	RÉSERVOIR CPL. ROUGE	DEPÓSITO CPL. ROJO
8	301			1	1	038 114 090		TANK KPL. ROT (HEIZUNG)	USA (EPA)	TANK CPL. RED HEATING	RÉSERVOIR CPL. ROUGE	DEPÓSITO CPL. ROJO
8	303	1	1	1	1	975 001 250		SCHALTER		SWITCH	INTERRUPTEUR	INTERRUPTOR
8	304	1	1	1	1	038 111 180		KURBELGEHÄUSE MS ROT	Heizung, heating	CRANKC. MAG. SIDE RED	CARTER-COTÉ MAGN. ROUGE	CÁRTER CIG. LADO MAG. ROJO
8	305	1	1	1	1	957 148 020		GENERATORANKER	SET	GENERATOR COIL	BOBINE GÉNÉRATRICE	BOBINA GENERADOR
8	306	1	1	1	1	038 146 030		ISOLIERKAPPE GELB		INSULATING CAP	CHAPE D'ISOLATION	CUBIERTO DE AISLADOR
8	307	3	3	3	3	913 340 205		SCHRAUBE	4X20	SCREW	VIS	TORNILLO
8	308	1	1	1	1	957 148 002		POLRAD KPL. GRIFFHEIZUNG		FLYWHEEL ASSY.	ROUE POLAIRE CPL.	VOLANTE ENCENDIDO
8	311	1	1	1	1	957 311 590		MASSELEITUNG	SET	EARTH CABLE	FIL DE MASSE	CONDUCCIÓN A MASA

PS-7310, PS-7310 H, PS-7910,  
PS-7910 H, PS-7310 , PS-7310  
H , PS-7910 , PS-7910 H

9

Sägeschienen, Sägeketten, Werkzeug  
Guide bars, saw chains, tools  
Guide-chaîne, chaînes, outils  
Rieles guía, cadenas sierra, herramientas

**DOLMAR**  
A member of the **Trakita** Group

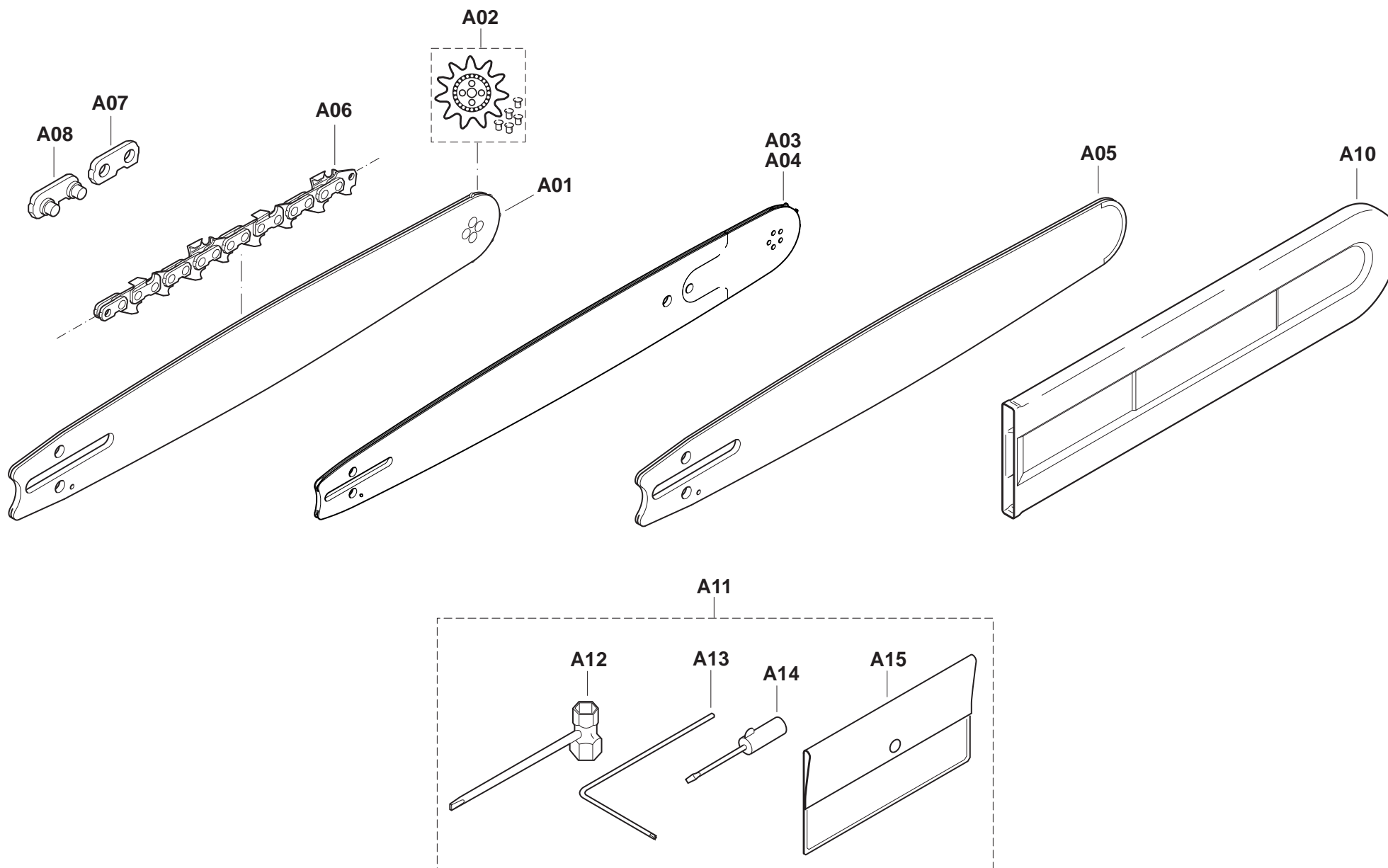

PS-7310, PS-7310 H, PS-7910,  
PS-7910 H, PS-7310 , PS-7310  
H , PS-7910 , PS-7910 H

9

Sägeschienen, Sägeketten, Werkzeug  
Guide bars, saw chains, tools  
Guide-chaîne, chaînes, outils  
Rieles guía, cadenas sierra, herramientas

**DOLMAR**  
A member of the **Takita** Group

Seite / Page	Pos.	PS-7310	PS-7310 H	PS-7910	PS-7910 H	PS-7910 (USA,CAN)	PS-7310 H (USA,CAN)	PS-7910 (USA,CAN)	PS-7910 H (USA,CAN)	Teil-Nr. Part No. No. de pièce No. de pieza	Hinweise Notes Renseign. Nota	Bezeichnung	Spezifikation Specification	Description	Désignation	Denominación
9	A01	1	1	1	1	1	1	1	1	415 038 655		STERNSCHIENE	3/8" .058" 38CM-15"	SPROCKET NOSE BAR	GUIDE À ÉTOILE	GUÍA CON ESTRELLA
9	A01	1	1	1	1	1	1	1	1	415 035 655		STERNSCHIENE	3/8" .058" 35CM-14"	SPROCKET NOSE BAR	GUIDE À ÉTOILE	GUÍA CON ESTRELLA
9	A01	1	1	1	1	1	1	1	1	415 045 655		STERNSCHIENE	3/8" .058" 45CM-18"	SPROCKET NOSE BAR	GUIDE À ÉTOILE	GUÍA CON ESTRELLA
9	A01	1	1	1	1	1	1	1	1	415 050 655		STERNSCHIENE	3/8" .058" 50CM-20" (72)	SPROCKET NOSE BAR	GUIDE À ÉTOILE	GUÍA CON ESTRELLA
9	A02	1	1	1	1	1	1	1	1	415 038 720		UMLENKSTERN KPL.	3/8" .058"	SPROCKET NOSE	ÉTOILE	ESTRELLA
9	A03	1	1	1	1	1	1	1	1	415 060 555		POWER MATCH SCHIENE	3/8" .058" 60CM-24"	SPROCKET NOSE BAR POWER MATCH	GUIDE À ÉTOILE POWER MATCH	GUÍA CON ESTRELLA POWER MATCH
9	A03	1	1	1	1	1	1	1	1	415 040 555		POWER MATCH SCHIENE	3/8" .058" 40CM-16"	SPROCKET NOSE BAR POWER MATCH	GUIDE À ÉTOILE POWER MATCH	GUÍA CON ESTRELLA POWER MATCH
9	A04	1	1	1	1	1	1	1	1	465 000 550		SCHIENENKOPF	3/8" .058" POWER MATCH NEUTRAL	SPROCKET NOSE	TÊTE DE GUIDE	CABEZAL DE BARRA
9	A05	1	1	1	1	1	1	1	1	415 070 455		PANZERSCHIENE	3/8" .058" 70CM-28"	SOLID NOSE BAR	GUIDE BLINDÉ	GUÍA BLINDADA
9	A05	1	1	1	1	1	1	1	1	415 050 455		PANZERSCHIENE	3/8" .058" 50CM-20"	SOLID NOSE BAR	GUIDE BLINDÉ	GUÍA BLINDADA
9	A05	1	1	1	1	1	1	1	1	415 060 455		PANZERSCHIENE	3/8" .058" 60CM-24"	SOLID NOSE BAR	GUIDE BLINDÉ	GUÍA BLINDADA
9	A06	1	1	1	1	1	1	1	1	528 099 772		SÄGEKETTE	3/8" .058" 50/53CM-20/21"	SAW CHAIN	CHAÎNE	CADENA
9	A06	1	1	1	1	1	1	1	1	528 099 784		SÄGEKETTE	3/8" .058" 60CM-24"	SAW CHAIN	CHAÎNE	CADENA
9	A06	1	1	1	1	1	1	1	1	528 099 794		SÄGEKETTE	3/8" .058" 70CM-28"	SAW CHAIN	CHAÎNE	CADENA
9	A06	1	1	1	1	1	1	1	1	528 099 756		SÄGEKETTE	3/8" .058" 35/38CM-14/15"	SAW CHAIN	CHAÎNE	CADENA
9	A06	1	1	1	1	1	1	1	1	528 099 760		SÄGEKETTE	3/8" .058" 38CM-15"	SAW CHAIN	CHAÎNE	CADENA
9	A06	1	1	1	1	1	1	1	1	528 099 768		SÄGEKETTE	3/8" .058" 45CM-18"	SAW CHAIN	CHAÎNE	CADENA
9	A07	1	1	1	1	1	1	1	1	558 093 000		AUßENLASCHE	3/8" .058"	TIE STRAP	ECLISSE EXTERIEURE	TIRA EXT.
9	A08	1	1	1	1	1	1	1	1	558 093 010		AUßENLASCHE MIT NIET	3/8" .058"	TIE STRAP WITH RIVETS	ECLISSE AVEC RIVETS	TIRA EXT. CON REMACHES
9	A10	1	1	1	1	1	1	1	1	952 030 180		KETTENSCHUTZ	80 cm	CHAIN PROTECTION	PROTECTION CHAÎNE	PROTECTOR DE CADENA
9	A10	1	1	1	1	1	1	1	1	952 020 160		KETTENSCHUTZ	60 cm	CHAIN PROTECTION	PROTECTION CHAÎNE	PROTECTOR DE CADENA
9	A10	1	1	1	1	1	1	1	1	952 020 150		KETTENSCHUTZ	50 cm	CHAIN PROTECTION	PROTECTION CHAÎNE	PROTECTOR DE CADENA
9	A11	1	1	1	1	1	1	1	1	957 004 002		WERKZEUG KPL.		TOOL CPL.	OUTILS CPL.	HERRAMIENTAS CPL.
9	A12	1	1	1	1	1	1	1	1	941 719 133		KOMBISCHLÜSSEL	SW 13/19	UNIVERSAL WRENCH	CLÉ COMBINÉE	LLAVE DE BUJIA
9	A13	1	1	1	1	1	1	1	1	940 827 000		WINKELSCHRAUBENDREHER	T27	ANGLED SCREW DRIVER	CLÉ ANGLE	LLAVE ANGULAR
9	A14	1	1	1	1	1	1	1	1	944 340 001		SCHRAUBENDREHER		SCREWDRIVER	TOURNEVIS	DESTORNILLADOR
9	A15	1	1	1	1	1	1	1	1	950 004 002		WERKZEUGTASCHE		PLASTIK BAG	POCHETTE EN PLASTIQUE	CÁRTERA HERRAMIENTAS

PS-7310, PS-7310 H, PS-7910,  
PS-7910 H, PS-7310 , PS-7310  
H , PS-7910 , PS-7910 H

**DOLMAR**



A member of the **Takita** Group

	<b>Zeichenerklärung</b>	<b>Key to symbols</b>	<b>Légende</b>	<b>Explicación de símbolos</b>
<b>=&gt; 1999999</b> <b>2000000 =&gt;</b> <b>2003.04 =&gt;</b> <b>TI 2003/07</b> <b>Acc.</b> <b>=</b> <b>{</b> <b>m</b> <b>Corr.</b>	Produktion bis Serien-Nr. Neues Teil ab Serien-Nr. Neues Teil ab Jahr / Monat Siehe Technische Information Jahr / Nr. Zubehör (nicht im Lieferumfang) Keine Serienausführung, jedoch verwendbar Beinhaltet Positions-Nr. Meterware Druckfehlerberichtigung	Production to serial number New part from serial number New part from Year / Month See Technical Infromation Year / No. Accessories (not included in the delivery inventory) No standard execution, may be used Contains item number Sold by the meter Error correction	Production jusqu'à n° de série Nouveau pièce à partir du n° de série Nouveau pièce à partir de année / mois Voir information technique année / n° Accessoires (non compris dans la livraison) Aucune exécut. en série, cependant utilisable contient n° de numéro Au mètre Rectification d'erreurs	Producción hasta N° de serie Pieza nueva a partir de N° de serie Pieza nueva a partir de año / mes Véase inform. técnico año / N° Accesorios (no incluido en la extensión del suministro) No es de serie, pero sirve Contiene pos N° Por metro Fe de erratas
	Änderungen vorbehalten	Specifications subject to change without notice	Changements sanas préavis	Mejoras constructivas sin previo aviso